



*An Online CPD Course
brought to you by
CEDengineering.ca*

HVAC Space Heating Systems

Course No: M06-025

Credit: 6 PDH

A. Bhatia



Continuing Education and Development, Inc.

P: (877) 322-5800

info@cedengineering.ca

HVAC - SPACE HEATING SYSTEMS

Maintaining comfort is not a matter of supplying heat to the body. Instead, it's a matter of controlling how the body loses heat. "Thermal comfort" is a measure of a person's satisfaction with his or her surroundings, and is achieved when a desirable heat balance between the body and surroundings are met. Since there is no single ideal comfort point for any group of people, a range of values are described as the ideal thermal zone. These conditions are:

1. Air temperatures between 60-72°F, dependant upon the type of activity being carried out, age of occupants and the level and quality of clothing;
2. Air temperature at feet level, not greater than 5.4°F below that at head level;
3. Airflow past the body is horizontal and at velocity ranging between 40 and 50 feet per minute. A variable air velocity is preferable to a constant one;
4. Room surface temperatures not above the air temperatures;
5. Relative humidity between 40%- 60%.

The heating system design can have lot of options; the three main considerations in the selection of a heating system are: 1) low installation cost, 2) low operating and maintenance cost, and 3) adequate control of space conditions.

In this course, we will categorize heating systems in several ways. First we will consider where the primary energy comes from. Then we will compare the various options and discuss the variety of ways used to deliver heat within the space and finally, some general guidelines on the energy conservation and application strategies for various buildings. The course is divided in six sections:

Section # 1	The Basics of Heat Loss
Section # 2	Application Considerations – Fuel Choices
Section # 3	Types of Heating Systems
Section # 4	Gas & Oil Fired Space Heating Systems
Section # 5	Hot Water Heating Systems
Section # 6	Electrical Heating Systems
Annexure # 1	Industry Standards & Codes
Annexure # 2	Heating Equipment Characteristics
Annexure # 3	Application Considerations for various systems
Annexure # 4	Energy Conservation & Load Reduction Strategies

This course reviews the above criteria in detail and is followed by a course summary and multiple-choice quiz at the end.

SECTION #1**THE BASICS OF HEAT LOSS**

In this section, we will examine

1. How heat loss occurs?
2. How to size the heating system?
3. How to extrapolate your heat loss results into an annual energy usage rate?
4. How to estimate the annual cost of heating?
5. Basis of selecting appropriate heating source.

How Heat Loss Occurs?

Heat loss occurs from a building envelope whenever the interior temperature exceeds the exterior temperature. The rate at which it occurs is affected primarily by the efficiency of the covering materials (glazing, roof, side walls, doors, window frames and end walls). Heat loss is typically expressed in terms of total British Thermal Units per Hour (BTU/h) and is given by:

$$Q = A \times U \times \Delta T$$

Where:

- Q = heat loss, BTUH or BTU/hr
- A = area of the surface, square feet
- U = heat transfer coefficient, BTUH per sq ft per °F
- ΔT = temperature difference between inside and outside, °F

For example: 10 sq. ft. of single glass with U value of 1.13, an inside temperature of 70°F and an outside temperature of 0° would have 791 BTU/h heat loss: $A (10) \times U (1.13) \times \Delta T (70 - 0) = 791 \text{ BTU/h}$.

The most commonly discussed parameters and the factors affecting heat loss are conduction, temperature and infiltration.

1. **Conduction** is heat flow through a material from hot to cold. The materials used in the construction of a building determine the level of conductivity. Insulating the building structure slows the flow of heat. R-value is a measure of insulation; *the larger the R-value, the lesser is the heat loss*. "U" factor is the inverse of "R" factor, (" U " = $1 / "R"$); *the lower the "U" factor, the less ability of the material to transfer heat; therefore, the lower the heat loss*.

2. **Temperature** difference between the inside and outside of the building is the primary cause of heat loss in the winter months. The greater this difference, the higher the rate of heat loss. Since most buildings are controlled to a constant inside temperature by the occupants, higher heat loss occurs when it is colder outside.
3. **Wind and infiltration** – Heat loss from a building can also occur through infiltration: the leakage of air into a building through cracks, poorly fitted windows and doors, chimneys and other breaks in the continuity of the enclosure. High winds can occur on cold nights, and when they do, heat loss can be higher because of air scrubbing the outside of the space covering. Winds can also force their way through cracks in the structure, causing infiltration and drafts. In fact, the studies indicate that up to one-third of the annual heating energy goes to heat this moving infiltration air. Shrubs and windbreaks to keep the high winds from impacting the walls will help reduce this energy loss.

Heating System Sizing

The first step in designing heating system is finding out how much heat is needed. The heating load of a space depend on climate, size, and style of building; insulation levels; air tightness; amount of useful solar energy through windows; amount of heat given off by lights and appliances; thermostat setting; and other operational factors. Together, these factors determine how much heat must be put into the space by the heating system over the annual heating season. This number, usually expressed as BTU per year, can be estimated by a heat loss calculation. The overall heat loss from buildings is divided into three groups:

1. The heat transmission losses through the confining walls, floor, ceiling, glass, or other surfaces,
2. Perimetric heat loss through floor slab, and
3. The infiltration losses through cracks and openings, or heat required to warm outdoor air used for ventilation.

Heat loss estimation shall be made on the worst scenario. The important points to note are:

- a. The heat loss calculations are made on most unfavorable but economical combination of temperature and wind speed.

- b. Credit for the heat of people present in the building is normally not taken since the building could be unoccupied.
- c. Internal heat gain from lighting and appliances is usually neglected.
- d. Inside design temperature for most commercial and residential spaces is 65°F.

Heat Loss from Building Envelope (wall, roof, glazing etc)

The hourly rate of heat loss from the building envelope is given by equation:

$$Q = U \times A \times (T_i - T_o)$$

Where

- Q = total hourly rate of heat loss in BTUH
- A = area of the surface, square feet; the value measured from building plan and elevation drawings
- U = heat transfer coefficient, BTUH per sq ft per °F; the value dependent on the thickness and materials of construction
- T_i = inside design temperature in °F; the recommended value is 65°F
- T_o = outside design temperature in °F; look up by geographical location and refer to ASHRAE handbook

Let's examine each one of these terms, starting from the bottom.

- 1) ***The outside design temperature (T_o):*** First step is to obtain data on the local micro climate of the region. This information is available from ASHRAE Handbook of Fundamentals or from the local airport database. As a basis for design, the most unfavorable but economical combination of temperature and wind speed is chosen. *Use of 99% values is recommended, which suggest that the outdoor temperature is equal to or lower than design data 1% of the time.* For example, the Pittsburgh, PA, 99% design temperature is 4°F. Only one percent of the hours in a typical heating season (about 30 hours total) fall at or below that temperature. Since most of these hours are during the night-time when most people are sleeping and because these extremes are buffered by the large storage mass of the building, these cooler periods usually go unnoticed. For general reference, the map below shows the lowest outside temperatures.

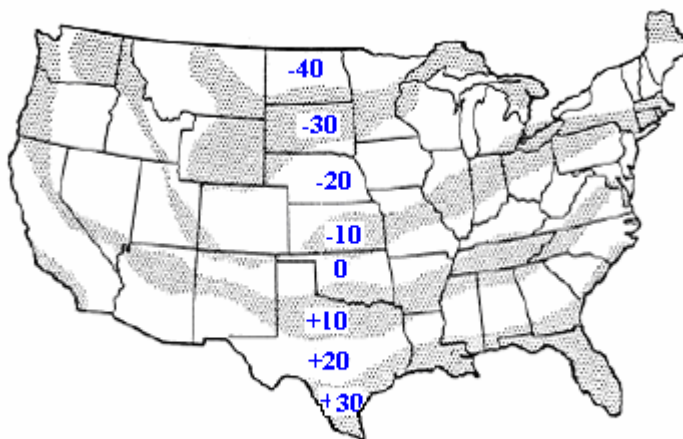

Winter Design Temperature Map

- 2) The **inside design temperature (T_i)** is traditionally taken as 65°F, because most buildings have people, lights, and equipment that will reduce the occupied heating requirement in comparison to the unoccupied winter night loads. But there are numerous exceptions such as warehouses and hospitals.
- 3) The **net area (A)** of each building section is determined from the drawings (in new construction) or from field measurements (in retrofit situations). In addition to the areas of the four walls, floor, and ceiling, we must also consider heat loss from doors and windows. Finally, we will need to determine the volume of the building as an easy way to estimate the rate of infiltration into the building measured in air changes per hour.
- 4) **The heat transfer coefficient (U -factor)** is a measure of the rate of heat loss or gain through construction materials and depends on the thickness and the nature of the material. This rate is the U-Factor (heat transmission coefficient) of a material. It indicates how many BTUs will flow through a material having a one-square-foot surface in one hour for each degree of temperature difference between inside and outside. The lower the U-factor, the greater the material's resistance to heat flow and the better is the insulating value. U-value is the inverse of R-value (hr sq-ft °F /BTU).

Mathematically, the U-value of a construction consisting of several layers can be expressed as:

$$U = 1 / \sum R$$

Where,

- ΣR is the sum of the thermal resistances for each component used in the construction of the wall or roof section. The R-value of the single layer can be expressed as:

$$R = 1 / C = 1 / K l_t$$

Where,

- C = layer conductance (BTU/hr sq-ft °F)
- K = layer conductivity (BTU in/hr sq-ft °F)
- l_t = thickness of layer (inches)

As an example, consider a section of a standard wall construction below:

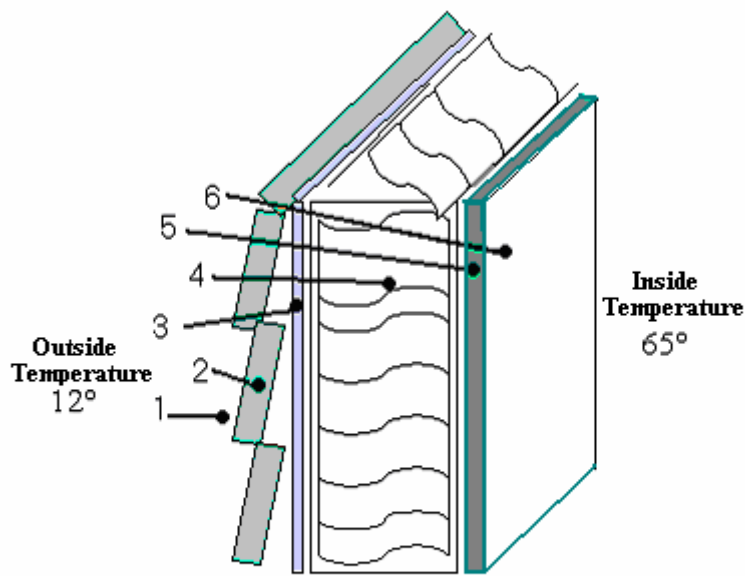

Wall Construction Details

There are 6 components contributing to the R-value:

1. Outside Air Film (15 mph) = 0.17
2. Wood siding (1/2 x 8") = 0.81
3. Sheathing (1/2" regular) = 1.32
4. Insulation (3-1/2" fiberglass) = 11.00
5. Gypsum board (1/2") = 0.45
6. Inside air film (still air) = 0.68

Adding the values gives a total resistance, $\sum R = 14.43$ (hr-ft²-°F / BTU) and therefore. U-factor is determined by taking the reciprocal of the R-value, i.e. $U = 1/\sum R = 1 / 14.43 = 0.07$ BTU / hr-ft²-°F.

The table below lists common construction materials and components with their average U-Factors.

Material	“U” Value (BTU / hr-ft ² -°F)	
Glass, single	1.13	
Glass, double glazing	.70	
Single film plastic	1.20	
Double film plastic	.70	
Corrugated FRP panels	1.20	
Corrugated polycarbonate	1.20	
Plastic structured sheet;		
16 mm thick	.58	
8 mm thick	.65	
6 mm thick	.72	
Roof	w/o ceiling	With ceiling
Concrete 2 inch thick without insulation	0.82	0.43
Concrete 2 inch thick with 1” insulation	0.25	0.20
Concrete 2 inch thick with 2” insulation	0.15	0.13
Concrete 4 inch thick without insulation	0.74	0.41
Concrete 4 inch thick with 1” insulation	0.23	0.19
Concrete 4 inch thick with 2” insulation	0.14	0.13
Metal deck without insulation	0.95	0.47
Metal deck with 1” insulation	0.24	0.20
Metal deck with 2” insulation	0.15	0.13
Wood 1” thick without insulation	0.50	0.32

Walls	No interior finish	Plaster surface
Corrugated iron on wood or metal frame	1.60	0.75
Transite, 3/8" thick on wood or metal frame	1.18	0.35
8 inch solid brick	0.48	0.45
12" solid brick	0.35	0.34

Note - Many insulating materials are rated based on "R" factors. To determine "U" factor from "R" factor simply divide 1 by R ($1/R=U$). Conversely, to convert U to R divide 1 by U ($1/U=R$).

Heat loss from floors on slab

A substantial amount of heat energy is lost out of the perimeter of a space through the ground below the perimeter walls and ends. The slab heat loss is calculated by:

$$Q = F \times P \times (T_i - T_g)$$

Where,

- Q = total hourly rate of heat loss in BTUH
- F is the heat loss coefficient for the particular construction and is a function of the degree days of heating; (unit - BTU/hr-ft²-°F)
- P is the perimeter of slab in ft
- T_i is the inside temperature in °F
- T_g is the ground temperature in °F

Note that the heat loss from slab-on-grade foundations is a function of the slab perimeter rather than the floor area. For a concrete slab-on-grade floor, the thermal resistance to heat loss into the ground is close to an R-value of 10 hr-ft²-°F/BTU (or $F = 1 / 10 = 0.1$ BTU/hr-ft²-°F), and the ground temperature is fairly constant at about 45°F in the winter ($65 - 45 = 20^\circ\text{F}$).

Perimetric heat loss is conductive heat loss that can be minimized by insulation below the frost line.

Infiltration Load

Wind pressure outside of a building continually forces a certain amount of air to infiltrate through openings around doors and windows. Additional air rushes in each time a window or door opens. This cold air must be included as part of the heat load and extra equipment capacity must be added to accommodate this extra load. The formula to be used is:

$$Q = \text{mass flow (lb/hr)} \times \text{specific heat (BTU/lb/deg F)} \times \Delta T \text{ (F)}$$

To convert from mass flow to CFM, you need to multiply by density and by 60 mins/hr.

$$Q = \text{volumetric flow (cubic feet/min)} \times 60 \text{ mins/hr} \times 0.075 \text{ lb/cubic foot} \times 0.24 \text{ BTU/lb/F} \times \Delta T \text{ (F)}$$

$$Q = \text{CFM} \times 1.08 \times \Delta T$$

Where,

- Q = total hourly rate of heat loss in BTUH
- CFM = outside air that enters, in cubic feet per minute
- 1.08 = a constant
- ΔT = temperature difference between inside and outside, °F

The rate of air infiltration is difficult to determine. For calculation purposes it can be estimated by using what is known as the “air change” method:

$$R = V \times C \times 1/60$$

Where,

- R = infiltration rate in cubic feet per minute
- V = room volume in cubic feet
- C = air changes per hour

Air changes are based on judgment, previous experience, and empirical data. A very tight building will lose about 0.5 air changes per hour; an average building is about 1.0 air change per hour; and a leaky older space can lose well over 2.0 air changes per hour.

When specific data and information are not available, infiltration may be assumed to average one air change per hour.

Ventilation Load

To expel smoke and odors, and to provide general ventilation, it is sometimes desirable to introduce outside air with a fan or blower rather than rely on air to “leak in”. Often this forced air ventilation is required by local codes; especially in spaces that are used for public purposes. It is also necessary to provide for the amount of air that is deliberately exhausted from spaces like washrooms, kitchens, spray booths, laundry rooms, etc.

When ducts bring outside air in directly to the intake side of a heater, this additional heat load must be figured into the overall determination of total heat capacity required.

Recommended summer ventilation rates vary but a common accepted rate is 8 cubic feet per minute (CFM) per square foot of floor space. Winter recommended ventilation rates are 1.5 CFM per sq-ft of floor space.

The formula for calculating ventilation load is:

$$Q = \text{CFM} \times 1.085 \times \Delta T$$

Where,

- Q = total hourly rate of heat loss in BTUH
- CFM = outside air brought in through the system, cubic feet per minute
- ΔT = temperature difference between inside and outside air, °F
- 1,085 = a constant

Note: Both the ventilation load and the infiltration load should be calculated but only the greater of the two should be included in the total heat-load estimate. In applying unit heaters for general applications, many contractors allow about 10% of total air quantity from outside air.

Heating Degree Days & Annual Heat Loss

When you use fuel or electricity for space heating, demand will tend to vary according to how cold the weather is. The heating degree-day (HDD) concept is used to determine the coldness of a climate and reflects the demand for energy needed to heat a building.

When the outside air is above a certain temperature your building won't need heating. This is what is called the 'base temperature' and in the US it's common to assume a value of 65°F. If the average outside air temperature on a given day is below this base temperature, you will need heat; and your heat requirement that day will be in proportion to the temperature deficit in degrees. For example, if the day's average temperature is

50°F, its HDD is 15 (65 – 50). If every day in a 30-day month had an average temperature of 50°F, the month's HDD value would be 450 (15 x 30).

Degree-day values are available from the U. S. Weather Bureau and the Canadian Meteorological Division, Department of Transport.

The yearly total of degree-day values for a given locality can be used to calculate a building's heat loss for an entire season with the following formula:

$$H = 24 \times Q \times D \div \Delta T$$

Where,

- H = heat loss in BTUs per heating season
- D = total number of degree days in season
- ΔT = the design temperature difference between indoor and outdoor temperatures
- Q = design heat loss in BTU/hr

The degree day method is probably the best way to estimate the annual heat loss and the building's fuel requirements. For example, Pittsburgh, PA, Columbus, Ohio, and Denver, Colorado have comparable annual degree days (about 6000 DD/year). It can be expected that the same structure in all three locations would have about the same heating bill. Move the building to Great Falls, MT (7800 DD/year), it would have a higher heating bill; but in Albuquerque, NM, (4400 DD/year), it would have a relatively lower heating cost.

From the above data, we can make an educated guess about the annual heat loss. How?

To determine the annual heat loss, divide the energy loss rate by the design temperature difference and then multiply it by 24 hours per day and the number of annual degree days (from the weather files for a particular location). For example, a house with a design heating load of 30,000 BTU/hr in Pittsburgh (outdoor design temperature of 4°F) will use: [30,000 BTU/hr x 24 hr/day / (65-4) (°F)] x 6000 DD/yr = 71 million BTU/yr.

SECTION #2 APPLICATION CONSIDERATIONS – FUEL CHOICES

In this section, we will examine:

1. The common heating fuels
2. Factors influencing the choice of heating fuel
3. Heat value of various fuels
4. Heating systems ranking

Common Heating Fuels

The most common fuels used for space heating are natural gas, propane, fuel oil and electricity.

The most frequently used unit of measurement for the energy content of the fuel is British Thermal Unit (BTU). One BTU is equal to the amount of energy it takes to raise the temperature of one pound of water by 1 degree Fahrenheit.

1. **Natural Gas:** Natural gas is the most prevalent fuel medium of space heating today in the United States. Natural gas delivered for heating purposes typically has a heating value between 800 and 1150 BTUs per cubic foot. The heating value is an important piece of information for:
 - Sizing a heater or furnace and the gas-supply piping for it;
 - Estimating gas consumption and the cost of operation.

Most gas heating appliances have heating capacities of between 40,000 and 150,000 BTUH.

1. **Propane:** Propane, or liquefied petroleum gas (LPG), can be used in many of the same types of equipment as natural gas. It is stored as a liquid in a tank, so it can be used anywhere, even in areas where natural gas hook-ups are not available. Consumption of propane is usually measured in gallons; propane has an energy content of about 92,700 BTU per gallon.
2. **Fuel Oil:** Several grades of fuel oil are produced having heating capacities varying between 56,000 and 150,000 BTU/hr. One gallon of gasoline contains about 124,000 BTU.
3. **Electricity:** The heating capacity of electric systems is usually expressed in kilowatts (kW). A kilowatt-hour (kWh) is the amount of electrical energy supplied by 1 kW of power over a 1-hour period. 1 kW of electric heating produces **3,413** BTU's of heat per hour.

Each of the heating options have pluses and minuses. Depending on the level of comfort and the operating costs, it's simply a matter of applying the best judgment to provide a safe and reliable system that will maintain a constant, comfortable indoor environment under all outdoor conditions.

Factors Influencing the Choice of Heating Fuel

Selecting the fuel and heating system best suited for your needs depends on many factors. These include: the cost and availability of the fuel or energy source; the type of appliance used to convert that fuel to heat and how the heat is distributed in your space; the cost to purchase, install, and maintain the heating appliance; the heating appliance's and heat delivery system's efficiency; and the environmental impacts associated with the heating fuel. Heating system design is often compromised by the first cost of equipment and the recurring fuel costs needed for operation. This should not be the sole measure for selecting a heating system. The broad comparisons on the choice should be based on various other system characteristics such as equipment efficiency, fuel source availability, required system capacity, fuel energy content in millions BTU per unit, environmental impact and heat response or recovery.

A brief description of fuel and heating system selection factors is discussed below:

- 1) **Fuel Availability** - The first step in the process of selecting space heating equipment involves determining the fuel to be used. Obviously, if only one fuel is available, no decision is necessary. If several fuels are available and one is natural gas, the choice is made simpler because natural gas offers the best combination of ready availability, reliability, continuity of supply, low cost, non-polluting combustion, and good control for accurate uniform heating. Where pipeline natural gas is not available, propane makes a sound alternative choice; it is a clean-burning, nonpolluting and controllable as natural gas. Although its cost may be higher on a per cubic-foot basis, propane has a higher heating value and is competitive on a per-BTU basis.
- 2) **Equipment costs** not only vary between heating systems, but can also vary significantly within the same class of equipment depending on the size and efficiency. In many cases, the extra cost of more efficient models can be recovered in three to five years due to energy savings. Most experts agree that higher first costs are justified if the energy efficiency investments yield payback within five years. This means if you pay an extra \$500 for a more efficient model, you should save \$500 in energy costs within five years to make it worthwhile. This means approximately 20% simple return on your investment. As utility costs increase, so will the return on your investment.

- 3) **Price of fuel:** This is not always easy to do without some help. You will need to know what your heating costs were for the last several years for the fuel you were using and compare that with the cost of the alternative fuel over the same period. Local consumer agencies should be able to help here.
- 4) **Comfort:** Comfort is defined by uniformity, heat response control and noise levels. A comfortable heating system may incorporate some radiant heating as well as convective. It may be difficult to obtain comfort levels if a purely radiant system is used (such as radiant panels) so a mixture of convective and radiant heating is desirable.
- To maintain adequate comfort conditions, a controllable heating system is necessary (e.g. automatic thermostatic controls on oil or gas-fired system or electrical heating system). Note that a solid fuel system cannot be easily controlled.
 - Heat Response factor means how quickly the system will supply heat to the space. A heating system with a good "heat response" time brings a room up to the human comfort zone more quickly. A convective heater has a quicker heat response when compared to the radiant heaters.
 - If noise levels in a room such as a library are to be at a minimum, then fan convectors are not a good option. Quieter form of heating options includes radiators, under-floor heating, natural convectors or a radiant ceiling.
- 5) **Occupancy –** A number of questions need to be answered about how the space to be heated is occupied and used. How many hours per day and how many days per week do people regularly use the space? Do the people usually sit (e.g. office) or do they engage in heavy physical work (factory)? Does the space store materials that are perishable? Does the space to be heated include sleeping quarters? (Equipment certified to ANSI Z83 must not be used to heat any space where people sleep.) Answers to these questions will determine what equipment to use, what temperature should be maintained and how much temperature variation is tolerable.
- 6) **Application and Type of Building:** There are many types of buildings each having a different application. Here are few notes that require the attention of architect, engineer or heating system designer:
- In some applications (e.g., theaters and churches), noise and vibration control are primary considerations.

- In other buildings (refineries, chemicals or spray paint booths), explosion prevention may be the primary consideration.
 - In textile facilities fire is the major concern and in food facilities, the need for hygiene conditions can eliminate several options.
 - Hospitals require clean environment; thus, filtered air heating may be necessary, usually in a full air conditioning system.
 - For warehouses, radiant heating may be a suitable option since the air temperature need not be high.
 - Museums and Archive Stores require constant control of room temperature and humidity - air-conditioning may be necessary.
 - In some buildings it is difficult to run services through (e.g. stone walls, solid concrete slabs); therefore, electrical heating may be used.
 - In some buildings like nursery schools and nursing spaces, if radiators are utilized, it is advisable that low surface temperature radiators are used.
 - In wet areas like shower rooms and bathrooms, under-floor heating has an advantage in that it keeps the floor dry.
 - Some buildings (like churches) may be intermittently used so electrical heating may not be completely ruled out. High temperature roof mounted quartz electric heaters have been used in this type of building.
 - Schools have limited wall space so under-floor heating or low temperature ceiling heating is sometimes used.
 - In general, large areas benefit from the quick warm-up of air heating. In buildings with large occupancy, a ventilation system may be necessary to provide adequate fresh air for occupants, e.g. concert hall, auditoria. Ventilation systems with ductwork require ceiling void space.
- 7) **Plant Space:** Room for plant and equipment, storage space for fuel, etc. are some of the considerations for selection of heating systems. While natural gas may be piped and electricity lines are fixed, space is required for storing the fuel oil and solid fuels. A decision needs to be made on putting the central heating unit in the basement if the unit is not prone to flooding or rooftop unit (RTU) if the noise level below is not an issue. A factory assembled RTU is the cheaper option, which provides better quality control, does not require valuable building floor space, and provides direct access to interior spaces via the ceiling plenum.

In very large facilities, all utility equipment such as an air-conditioning plant, heating and cooling equipment, emergency electrical generator, fire safety systems, and often electrical supply transformers, Motor Control Centers (MCC) and Lighting Control Centers (LCC) can be located in a remote mechanical room. This allows for a better central management of the system operation, but is more expensive to build.

- 8) **Let Buildings:** Most landlords prefer the tenant to look after payment of their own heating bills. Individual meters for gas or electricity in a block of flats means that the tenants are responsible for the payment of bills. In a large office building with several tenants, electrical or natural gas heating is easy to measure in zones. Hot water heating system is cumbersome to divide. In let buildings, some form of a billing arrangement needs to be in place to charge tenants. This essentially requires a study on the quality of available instrumentation, ease of measurement and reliability of readings.
- 9) **Appearances:** In some buildings, the designer may require the heating system to be totally hidden, e.g. under-floor heating, heated ceiling or air heating. In some buildings the designer may wish to make a feature of the heating system or heat emitters, e.g. a warm air ductwork system painted in a bright color or concealed in a reflected ceiling plan. In some areas, like parametric lengths of building, cast iron radiators may be the choice. For Rooftop units (RTUs) the designer needs to integrate the unit into the architectural theme of the building so that it looks like it is supposed to be there, not just added as an after-thought.
- 10) **Efficiencies of heating equipment** are rated by different methods such as the Heating System Performance Factor (HSPF), Annual Fuel Utilization Efficiency (AFUE) or Thermal Efficiency/Combustion Efficiency Factor (E_t/E_c). In all cases, the higher the rating number, the more efficient is the unit.

The Federal Energy Agency requires all gas and oil fired furnaces be given operating efficiency ratings, such as the annual fuel utilization efficiency (AFUE). For combustion furnaces such as gas or oil, an AFUE rating of 8.1 or higher is considered good.

For electric resistance heating, although heat is generated almost at 100 percent efficiency, it is very costly on \$ per BTU heat release compared to other options. This is because first we generate electricity by thermal energy at 35 to 50% efficiency and than using it again for heating. The high operating cost of electricity must be considered to get an accurate picture of the system economics.

An efficient method of using electric energy as a heating source is the use of heat pumps. For air-to-air heat pumps (the heat exchanger is cooled or heated by air), a rating of 3.2 is considered satisfactory. For water-source heat pumps where the heat exchanger is heated or cooled by water, a rating of 3.8 is considered good. If rated by the HSPF method, 6.8 or better is considered satisfactory for heat pumps.

11) **Transport Media:** Another way of grouping heating systems is by the transport media used to get the heating energy to the distribution point. Heating fuels are normally handled in one of the following ways: Some fuels (such as fuel oil in a tank or coal in a bunker) are stored or warehoused, while other fuels (such as natural gas or electricity) are point-of-use fuels. Point-of-use fuels are delivered through utility piping or wiring networks, and are metered and billed after consumption. Stored fuels are paid for when purchased. Stored fuel suppliers are not regulated as closely or carefully compared to point-of-use fuel suppliers. As a result, prices for stored fuels tend to fluctuate more widely with market conditions. Point-of-use suppliers are normally regulated by state agencies and are restricted to rate schedules that tend to lag the market response of stored fuels. Electricity can be transported directly via wires.

12) **Environmental impact:** This factor considers air pollution and the best use of resources. The products of combustion of oil, coal and gas pollute the atmosphere.

- Coal is probably the worst offender since carbon dioxide contributes to the greenhouse effect and sulphur dioxide causes acid rain. Smoke causes urban smog and soot and ash adds to the problem. Oil produces contaminants to a lesser extent and gas is probably the best of the three.
- Using electricity is of little benefit because power stations burn fuel to produce electricity. For example, to generate one kilowatt hour of electricity in a coal-fired plant will require burning one pound of coal. This produces about three pounds of carbon dioxide (a greenhouse gas) and four ounces of sulfur dioxide (which contributes to acid rain).
- A totally 'green' source of heat may be solar energy if you live in an area with plenty of sunshine.

13) **Safety:** Ensure all apparatus is approved and meets standards and regulations. You should be aware of the following hazards when considering a heating system:

- Fires and burns caused by contact with or close proximity to the flame, heating element, or hot surface area.

- Poor safety record of some open gas and coal fires as well as paraffin heaters.
- Fires and explosions caused by flammable fuels or defective wiring.
- Indoor air pollution caused by improper venting or incomplete combustion of fuel-burning equipment.
- Carbon monoxide poisoning caused by improper venting of fuel-burning equipment

14) **Security of Supply of Heat Source:** Some fuels at certain times may be liable to unsecured supply, e.g. oil prices can fluctuate. It may be advisable to have a dual fuel system so that burners can easily be changed over to burn the cheaper or more readily available fuel.

Alternative sources of energy are not always secure, e.g. the wind doesn't always blow on a wind farm. The sun doesn't always shine if the system relies on solar panels. A hybrid system is more secure, otherwise back-up boilers can be used.

15) **Fluctuating Heat Demand:** In some buildings the demand for heat fluctuates widely throughout the day. To meet this demand economically, a modular system such as multiple unit heaters or electrical units may be a good option. This means that the required number of boilers is automatically switched on to meet the demand.

16) **Industrial Waste Heat:** In some industrial units, heat is available from the process, e.g. condensate, a by-product of steam or high temperature exhaust flue gases. Waste heat recovery equipment could be utilized to generate hot water or steam, which can be used to warm air in a heat exchanger. There are many ways in which waste heat can be utilized to pre-heat water or upgrade in heat pumps for further use in space heating.

17) **Maintenance:** Maintenance is very important with the heating systems because there are many pieces of equipment that can cause problems. With fuel fired equipment, the heat exchanger surfaces have to be cleaned and the burner has to be maintained and adjusted. In case of a hot water system, the water quality needs to be assured to prevent scaling. The electrical system does not have such problems other than routine switchgear maintenance.

18) **Financial Rebates/Subsidies:** Some gas and electric utilities offer rebates or low interest loans if certain systems are installed. Electric utilities prefer high efficiency heat pumps using heat recovery units to improve water heating. Gas utilities prefer efficient combinations of gas space and water heating systems. If rebates or low interest loans are offered, it could make the "equipment cost" factor more favorable.

Heating Values

The term “heating value” refers to the amount of heat generated by burning fuel completely. Heating value is expressed in energy per unit of the substance, usually mass, such as: BTU/lb, BTU/gallon, BTU/ton or BTU/kWh.

The table below provides a list of typical heating fuels and the BTU content in the units that they are typically sold in the United States. The figures below are for guidance only; commercial and industrial users should obtain more precise values from their fuel vendors. The exact heating value for a specific gas can be obtained from the supplying utility.

Average BTU Content of Fuels	
Fuel Type	No. of BTU/Unit
#2 Fuel Oil	140,000/gallon
#6 Fuel Oil	150,500 /gallon
Diesel	137,750/gallon
Kerosene	134,000/gallon
Electricity	3,412 per kWh
Natural Gas*	850,000 - 1,150,000/thousand cubic feet
Propane	91,330/gallon
Wood (air dried) *	20,000,000/cord or 8,000/pound
Pellets (for pellet stoves; premium)	16,500,000/ton
Kerosene	135,000/gallon
Coal	28,000,000/ton

Note that the energy content values may vary drastically, especially for wood and coal. As an energy system designer, you must learn the purchasing units associated with each

energy source. Rounding things off can make it a little bit easier. For example, natural gas contains about 1000 BTU per cubic foot. So, one hundred cubic feet (CCF) contains about 100,000 BTU. A gallon of fuel oil delivers almost 100,000 BTU per gallon. Knowing the unit efficiency allows you to calculate the original content.

Heating Values - A More Detailed Discussion

The heating values provided in the table above are the "higher" or "gross" heating values of the fuels as estimated by the Energy Information Administration in the Annual Energy Review 2001.

"Higher (or gross)" heating values are commonly used in energy calculations in the United States. "Net" or "lower" heating values may also be used. The difference between the two values is the amount of energy that is necessary to vaporize water that is contained in the fuel or created in the combustion process when hydrogen in the fuel is combined with oxygen to form water vapor. In general, this difference can range from as little as 2 percent to as much as 60 percent, depending on the hydrogen or moisture content of specific fuels. The heat energy contained in the water vapor is generally lost as the combustion gases leave the appliance vent or chimney. Some types of combustion appliances, however, such as high efficiency "condensing" forced-air furnaces, are able to capture much of the heat contained in the water vapor before it leaves the furnace vent (thus the term "condensing"). *Since electricity is not burned in a heating appliance, the two values are equal.*

*Natural gas is the most common space heating fuel and typically has a heating value somewhere between 800 and 1150 BTUs per cubic foot. The heating values show considerable variation for several reasons. First, natural gas from different sources can contain different proportions of methane, ethane, propane, and butane. The more carbon and hydrogen atoms there are in a molecule of gas, the greater its heating value. This means that, as the percentage of ethane, propane, and butane increases, the heating value increases. Second, natural gas may contain varying amounts of nitrogen; an inert gas that does not burn at all. The greater the amount of nitrogen present, the lower the heating value will be.

*Wood heating values can vary significantly. The most important factor affecting useful BTU content is the moisture content of the wood. Well-seasoned, air-dried wood will typically have a moisture content of around 20 percent (when compared to a "bone dry" sample of the wood). *A very rough approximation of the effect of moisture content on the heating value is for every percent increase in moisture content (relative to a bone-dry sample), there is a one percent decrease in the heating value.*

How to equate the heaters to the heating values?

For heating equipment to do its job, it must receive the necessary number of BTUs per hour. This required BTUH input rate usually appears on the nameplate of the device. It can be converted to fuel input rate (say gas flow rate) by using the heating value (obtainable from the supplying utility) and the following formula:

$$R = I \div H$$

Where:

- R = gas flow rate in cubic feet per hour;
- I = input rate in BTUs per hour;
- H = heating value of gas in BTUs per cubic foot.

Example calculation:

A heater with an input rating of 150,000 BTUs per hour is to be supplied with gas having a heat value of 1000 BTUs per cubic foot. The heater will use approximately 150 cubic feet of natural gas per hour ($150,000 \div 1000 = 150$).

How to equate the fuels based on heating values?

The average BTU content of fuel values make comparisons of fuel types possible. For example:

The heat content of one gallon of fuel oil #2 having a heat value of 140000 BTU's roughly equals that of 41 kWh of electricity, 137 cubic feet of natural gas, 1.5 gallons of propane, 17.5 pounds of air-dried wood, 17 pounds of pellets, a gallon of kerosene, or 10 pounds of coal.

One million BTU is the heat equivalent of approximately 7 gallons of No. 2 heating oil or kerosene, 293 kWh of electricity, 976 cubic feet of natural gas, 11 gallons of propane, 125 pounds of air-dried wood, 121 pounds of pellets, or 71 pounds of coal.

The efficiency of the heating appliance is an important factor when determining the cost of a given amount of heat. In general, the efficiency is determined by measuring how well an appliance turns fuel into useful heat. (The condition of the heat distribution or delivery system also affects the overall system efficiency.) Many types of space heating appliances must meet minimum standards for efficiency developed by the U.S. Department of Energy. The table below provides average efficiencies for common heating appliances.

Estimated Average Fuel Conversion Efficiency of Common Heating Appliances

Fuel Type - Heating Equipment	Efficiency (%)
Coal (bituminous)	
Central heating, hand-fired	45.0
Central heating, stoker-fired	60.0
Water heating, pot stove (50 gal.)	14.5
Oil	
Cast iron head burner	60.0
Flame retention head burner	70 - 78
High static replacement burner	75 - 82
New standard furnace	78 - 86
Mid efficiency furnace	83 -89
High efficiency condensing furnace	85 - 95
Typical central heating	80 -85
Water heater (50 gal.)	60
Gas	
Conventional furnace	60.0
Vent damper with non-continuous pilot light	62 - 67
Mid efficiency furnace	78 -84
High efficiency condensing furnace	89 - 97
Typical central boiler	85.0
Minimum efficiency central furnace	78.0
Room heater, unvented ^{note 1}	99.0
Room heater, vented ^{note 1}	65.0
Water heater (50 gal.)	62.0
Electricity	
Baseboard, resistance	100
Central heating, electric furnace-forced air	100
Central heating, air source heat pump ^{note 2}	200+
Central heating, ground source heat pump ^{note 2}	300+
Wood & Pellets	
Franklin stoves	30.0 - 40.0
Stoves with circulating fans	40.0 - 70.0
Catalytic stoves	65.0 - 75.0
Pellet stoves	85.0 - 90.0

Note 1*: Most of the appliance efficiencies given in the table above roughly account for the net heating value of fuels used in a vented appliance (i.e. one that has a chimney). An un-vented space heater, such as a kerosene heater or a natural gas fireplace insert, delivers nearly all of the heating value of a fuel to the space in which it is located. It also puts all the products of combustion including carbon dioxide, water vapor, and small

amounts of carbon monoxide, sulfur dioxide, and nitrous oxides into the room. These types of heating units generally require that a window be opened (slightly) for safe operation, which reduces their overall heating capability.

Note 2*: Heat pumps are measured by coefficient of performance (COP). A COP of 1.5 means that the equipment has an efficiency of 150%. It can be over 100% because heat pumps move heat from outside to inside, instead of creating it.

Comparing Fuel Costs

Comparing fuel costs is generally based on knowing two parameters: the efficiency of the appliance and the unit price of the fuel as follows:

1. Convert the BTU content of the fuel per unit to millions of BTU by dividing the fuel’s BTU content by 1,000,000. For example: 3,413 BTU/kWh (electricity) divided by 1,000,000 = 0.003413 million BTU per unit.
2. Use the following equation to estimate energy cost:

$$\text{Energy cost (\$ per million BTU)} = \text{Cost per unit of fuel} \div [\text{Fuel energy content (in millions BTU per unit)} \times \text{Heating system efficiency (in decimal)}]$$

The table below provides heat costs for different fuels and heating equipment.

Heating Equipment	Fuel	Fuel Cost (Note #1)	Fuel energy content (in million BTU per unit)	Heating System Efficiency (Note #2)	Heat Cost in \$ per million BTU (Note #3)
Resistance Baseboard	Electric	\$0.086 per kWh	0.003412	0.99	= \$25.46
Medium Efficiency Furnace	Natural Gas	\$9.96 per thousand cubic feet	1.03	0.90	= \$10.74
Medium Efficiency Furnace	Fuel Oil	\$1.25 per gallon	0.14	0.85	= \$10.5
Medium Efficiency Furnace	Propane	\$1.09 per gallon	0.0913	0.85	= \$14.05

Note #1: The fuel costs used are the national annual average residential fuel prices in 2007 according to the Energy Information Administration (EIA), U.S. Department of Energy. Prices will vary by location and season.

Note #2: The system efficiencies used are assumed examples only.

Note #3: Energy cost (\$ per million BTU) = Cost per unit of fuel ÷ [Fuel energy content (in millions BTU per unit) × Heating system efficiency (in decimal)]

Rule of Thumb Estimation of Annual Heating Cost

To convert BTU/yr values into dollars per year for the annual heating cost, we have to check how much energy costs. Again these values vary widely, depending on the season, geographic location and type of fuel. This assumption is too general to use for making large economic decisions, but it is certainly easier than trying to keep up with these constantly changing values.

For simplicity, consider all energy will cost exactly \$10 per million BTU. At today's energy prices, this average value is high for gas heat (by about a factor of 2), about right for fuel oil, and low for electric resistance heat (by about a factor of 2). The reason for this is that natural gas, for all practical purposes, is a raw commodity, while electricity is a value-added commodity. In other words, electricity is generated by raw commodities, including natural gas.

Even these prices vary substantially across the nation. Natural gas in New York sells for almost three times the price in Colorado and Louisiana. Electricity on Long Island costs almost ten times more than the price that Bonneville Power Administration gets for their hydroelectric power in Montana.

So in the Pittsburgh example we have discussed earlier (refer to Part 1, heating degree days) using 71 million BTU/yr, we would calculate the heating cost to be $71 \times \$10 = \710 per year. But in reality the heating cost might range from under \$350 for gas heat to over \$1400 for electric resistance heat.

Heating Fuels Ranking

The heating systems are ranked based on survey ratings from a group of design professionals, facility managers and contractors. In determining the overall rank of various systems, more weight is given to the "efficiency and fuel cost" factor.

The table below may serve as a decision-making guide.

Heating System	Equipment Cost	Efficiency & Fuel Cost	Environment Impact	Heat Response	Overall Rank
Natural Gas	4	1-3	2	1	1
Heat Pump (Air to Air)	7	2-4	4	9	2
Heat Pump (Water Source, Geothermal)	10	1-3	4	6	3
Heating Oil	5	2-5	5	1	4
LPG (Propane/Butane)	4	8	4	1	5
Wood Stoves	4-8	2-6	2-4	4	6
Wood Fireplaces	7	5-10	6-10	5-8	7
Electric Resistance (Strip)	3	10	10	3	8
# Rating Scale: 1 = best value or condition; 10 = poorest value or condition					

1) Ranked first are the natural gas heating systems:

The natural gas heating systems are the most effective systems where they are available. The natural gas systems have high efficiencies, low fuel costs, low environmental impacts, quick heat response, and moderate equipment costs and are relatively safe. They are clean burning, easy to use, and often the lowest cost per delivered energy. More efficient models have electronic ignitions as opposed to pilot lights. Natural gas is the most popular heating source for locations where it is available.

2) Ranked second are the air to air heat pump systems:

Air to air heat pump systems are generally efficient to operate, but initial equipment cost is usually higher and heat response is slow. A heat recovery unit can be added to improve the performance of the water heater. Where resistance costs more than fuel fired systems on a BTU-for-BTU basis, heat pumps may be a more cost-effective alternative, especially where heat pumps can also provide space cooling, dehumidification, or recover building or waste-water waste heat. The drawback is that the heat pump units are least efficient when outdoor is coldest and sometimes a standby electric resistance heating is added for such periods.

3) Ranked third are the geothermal heat pump systems:

Water source or geothermal heat pump systems use heat exchangers to recover heat from or release heat to ground water or earth. Systems using pumped well water may not be allowed in some water districts and may have scaling problems. The cost of these systems is generally highest, but comparable to natural gas in terms of efficiency and cost effectiveness to operate. Environmental impact is moderate; heat response is usually better than air to air heat pumps.

4) Ranked fourth are the fuel oil systems:

Fuel oil heating systems have moderately high efficiencies, moderate initial costs, relatively high environmental impact, and high heat recovery response. Fuel oil shares many of the same characteristics as gas, but requires on-site storage of fuel and a fuel unloading site. These deliver warm comfortable heat to spaces and are available in up-flow, down-flow and horizontal configurations.

5) Ranked fifth are the liquefied petroleum gas systems:

Liquid petroleum gas systems, such as propane and butane, have a moderately low initial cost, relatively high fuel cost, moderate environmental impact and high heat response. In general, the same technologies and comments apply to propane as to natural gas, with slight differences in the efficiencies. Propane has a lower hydrogen level than natural gas. About 3% less energy is tied up in the form of latent heat with propane systems than with natural gas. This means that conventional and mid-efficiency propane furnaces can be expected to be slightly more efficient than comparable natural gas units. On the other hand, propane's lower hydrogen content makes it more difficult to condense the combustion products, so that propane-fired condensing furnaces will be 2-3% less efficient than the same unit fired with natural gas. While all current heating equipment has built-in safety features and are installed

to rigid code requirements, LPG systems are less safe than others as this gas is heavier than air.

6) Ranked sixth are the wood stove systems:

Wood stove systems have a wide range of ratings depending on efficiency. Catalytic wood stoves with combustion efficiencies near 90 percent are considerably more expensive than standard wood stoves with combustion efficiencies of 20 to 40 percent. Handling wood and ashes is an inconvenience. Wood stoves have a high initial cost and, with the exception of catalytic stoves, the environmental impact is higher than gas, oil or heat pump heating systems. The heat response of wood stoves is moderate. Coal and wood-burning systems are only used in very large installations, where the lower fuel costs can justify the higher installation costs and higher operating costs.

7) Ranked seventh are the wood burning fireplaces:

Wood burning fireplaces have negative or very low efficiencies unless properly designed. The fireplaces are mainly used for aesthetics. Handling wood, disposing of ashes and increased risk of fire due to sparks and chimney fires are problem areas.

8) Ranked eighth are the electric resistance heating systems:

Electric resistance heating is costly to operate and has tremendous impact on the environment. Though electrical heating offers consumers a number of advantages, such as they are cheap to buy, least expensive to install, 100% efficient (i.e. all the energy is converted into heat), safer than fuel fired systems, a clean form of heating and easy to control with a thermostat, it has a set of problems. The environmental impact of using resistance heating is high and heat response is moderate. Since most electricity is produced from oil, gas, or coal generators that convert only about 30% of the fuel's energy into electricity and after accounting losses due to transmission and distribution, converting electricity back to heating doesn't make sense. The use of electric resistance heating should never be recommended as a policy measure.

SECTION #3 TYPES OF HEATING SYSTEMS

There are almost endless variations and combinations of equipment that can be utilized to create the best system. Every type of heating equipment has its strength and limitations. Depending on the level of comfort and the operating costs, you'll need to choose the style of system that integrates best with your facility requirements. It's simply a matter of determining your requirements and researching the best options with expert design professionals.

In this section, we will examine:

1. The heating methods
2. Types of heating systems
3. Types of heat distribution systems
4. System design decisions - central or zoned systems

THE HEATING METHODS

Space heating engineers are usually interested in distributing heat throughout the space of a building or enclosure. Most forms of space heating fall into either Radiant or Convective heating. Both these methods are effective in space heating and; therefore, it is important to understand the basic fundamentals.

Radiant Heating

Radiant heating systems utilize infra red radiation to heat objects, people and surfaces. Anyone who has warmed themselves by a hot wood stove or warmed their hands at a camp fire has experienced radiant heat. It is also demonstrated by standing in the sun on a winter's day; or walking near a brick wall that has been exposed to the sun during the day. In both examples, although the air may not be warm, you are able to feel the heat energy radiating from these surfaces.

Radiant heat directly heats objects in the room, but does not directly warm the room air. These are appropriate, if your rooms have large open spaces or high ceilings, or are particularly draughty.

Advantages of Radiant Heating

- Heat can be applied only to the area required.
- No air movement is caused by the system itself, therefore unwelcome draughts are minimized and dust movement is reduced.
- Because of radiant heat transfer, vertical temperature stratification is reduced.

- Lower operating costs should be achieved because of the localization of heating compared to convection systems.

Disadvantages

- An unobstructed space above floor level is necessary for an effective installation. The presence of ductwork, pipes, overhead conveyors and other equipment may sometimes limit full utilization of radiant heating.
- In certain applications where minimum ventilation rates is critical, a combination of convection heating (or the ventilation of intake air) and radiant heating is required.

Convective Heating

Convective utilizes air circulation to transfer heat and involves two basic principles: a) cold air displaces warm air; and b) warm air rises in the presence of cold air. These are either free or forced type.

- Natural Convection systems rely on the buoyancy of heated air to provide circulation throughout the space. The most common examples are the steam radiator and the baseboard unit.
- Forced Convection systems have a fan to force the air to circulate. Unit heaters and other fan/coil units are the common examples. These units allow the introduction of outside air and provide air filtration.

To maximize efficient use of the heat energy, it is important to force the mixing and circulation of these warm air layers.

The Advantages of Convective Heating:

- Convectors are used to heat up spaces more quickly than radiators.
- The convective units ensure that warm air is evenly distributed throughout the structure.

Disadvantages:

- The air heaters attempt to heat the entire space including people, hardware and all of the air within the space.
- The high discharge air volumes can cause unwelcome draughts which may reduce the perceived heating effect.

- Because of their usual overhead location severe vertical temperature stratification can occur with ceiling temperatures as much as 30°C above floor temperature.
- High volume air movement can also cause dust problems which could affect product quality particularly in product coating operations.

Convection heaters are appropriate if your space is insulated, well sealed against draughts and have average ceiling heights. They should be avoided in draughty rooms, rooms with high ceilings or areas with open stairwells. Convective heating is typically the most common form of heating in majority of facilities.

TYPES OF HEATING EQUIPMENT

There are two broad classification of heating equipment:

1. Combustion equipment, where heat is generated by the combustion of fuel in a furnace under careful air/fuel control. The heat of combustion is recovered in some form of integral heat exchanger and is distributed via a supply air ductwork. Another form of combustion equipment is the boiler, which provides heat through a hydronic distribution system (hydronic systems are also referred to as hot water systems).
2. Electric equipment, where the space heaters supply heat through an electric resistance element that convert electricity to heat with almost 100 percent efficiency. Another form is a heat pump, which extracts heat from the air, ground or water and usually delivers it through a forced air distribution system.

Efficiency Terminology

When shopping for heating equipment, it is important that you understand the common terminology used to describe different types of equipment. There are several types of efficiency terms used when describing heating equipment. The most common terms used to describe heating equipment are as follows:

1. **Combustion Efficiency:** This term is the most basic description of efficiency. It denotes the percentage of fuel burned and turned into heating energy.
2. **Thermal Efficiency:** This term is a measurement of the actual amount of available energy that transfers into the heating medium. It is derived by operating a piece of equipment at a steady state and measuring how much fuel is used vs. how much useable heat comes out. It is most typically used in reference to boilers.
3. **Distribution Efficiency:** This is the measure of efficiency of how well the heating equipment actually delivers the heat energy (BTUs) to your space and structure.

This expression addresses how energy is distributed and transferred to the objects requiring heat.

Distribution efficiency is greatly affected by the system(s) you select, and how you utilize your equipment. Some examples:

- a. Forced hot air systems' distribution efficiency is largely dependent upon the means of air circulation used in the space.
- b. Infrared systems, properly installed, can transfer heating energy very well to crops without the necessity of air circulation.
- c. With hot water, distribution efficiency is affected tremendously if the supply and return lines are poorly installed or are not insulated.
- d. Some hot water systems deliver heat much more efficiently than others. Finned pipes heat faster than bare pipes.
- e. With hot water, a high efficiency distribution system coupled to a poor efficiency boiler may be better than a high efficiency boiler with poor efficiency distribution.

Look at all facets of heating system efficiency when making heating equipment purchases along with other selection factors.

DISTRIBUTION SYSTEMS

There are three types of distribution systems.

1. A forced air system circulates warmed or cooled air around the house through a network of ducts. It also provides a means of distributing ventilation air.
2. Space heaters, though not technically a distribution system, provide direct heat to the room in which they are located.
3. A hot water (hydronic) system distributes heat through hot water pipes and radiators.

Forced Air Systems

Forced-air (convective) systems also referred to as "a central heating system" in commercial terminology utilize a series of ducts to distribute the conditioned heated or cooled air throughout the whole space. The heat source is either a furnace, which burns a gas, oil or an electric heat pump. Some forced heating systems utilize hot water or steam as heating source. A blower, located in a unit called an air handler, forces the

conditioned air through the ducts. Unless fresh air is piped in from outside, the system will re-circulate 100% of the air.

The indoor temperature is automatically controlled by a thermostat. Two important considerations are location and type. Central systems are normally controlled by a single thermostat. To achieve proper temperature control, the thermostat must be located in an area where it will sense the “average” indoor temperature. Locations exposed to localized temperature extremes (outside walls, drafts, sunlight, hot ducts or pipes, etc.) should be avoided.

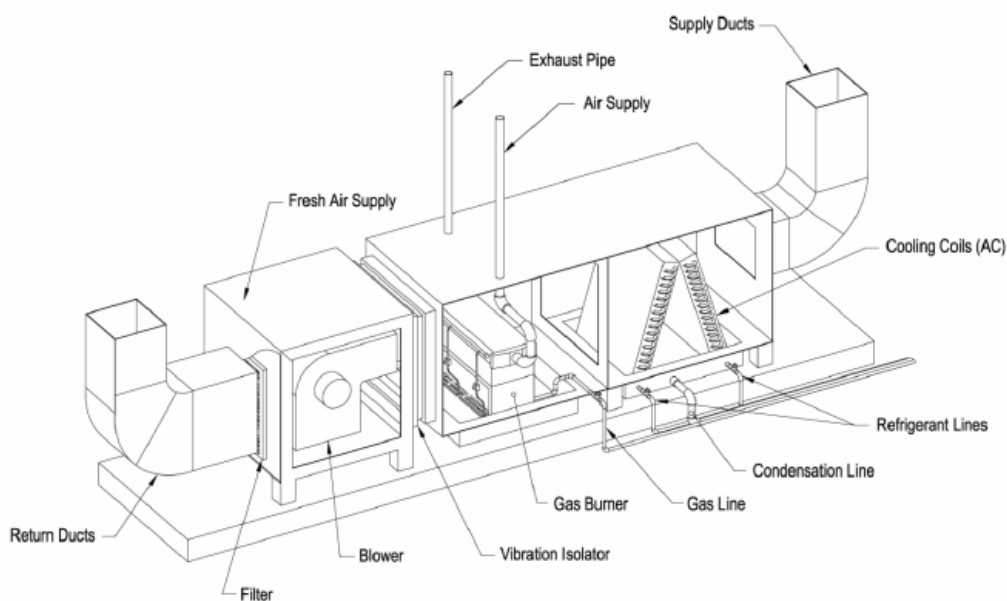

Forced Flow Heating Air Handler

The figure above shows an air handler equipped with gas fired furnace. Another form of forced air system is the piped system using a heating coil. Instead of a gas burner, hot water is circulated from boiler to the heating coils which heat the air.

The advantages to the forced air systems are numerous. The air can be heated, cleaned, sterilized, humidified, or cooled. If return air ducts are strategically located, this will reduce heat loss by recycling the warmest air back in to the system that collects at upper areas of the room.

Forced warm air systems have some disadvantages. Air coming from the heating registers sometimes feels cool (especially with certain heat pumps), even when it is warmer than the room temperature. There can also be short bursts of very hot air, especially with oversized units. Ductwork may transmit furnace noise and can circulate dust and odours throughout the indoor spaces. Ducts are also notoriously leaky, typically raising a space's heating costs by 20% to 30%.

Types of Forced Air Systems

The most economical and energy efficient central heating systems are either:

1. High efficiency, natural gas ducted heaters;
2. Natural gas hydronic systems;
3. Reversible-cycle heat pump air-conditioning system; or
4. Off-peak electric in-slab heating

When choosing gas systems, look for the energy rating label - the more stars you see, the better the performance, and the more money you'll save on your energy bill.

The table below compares various central heating systems per 1500 sq-ft space.

Central Heating System (1500 ft ²)	Description	Approx. purchase/install price	Annual Heating Costs (note 1)*
Ducted natural gas	Circulates warm air around the space.	\$4,000 - \$6,000	4-5 star rating: \$110-\$270 1-2 star rating: \$160-\$360
Reverse-cycle air conditioner	Circulates warm or cool air around the space.	\$8,000 - \$12,000	\$120-\$220
Hydronic Heating	Water is heated in a boiler (fuelled by natural gas, LPG, wood or off-peak tariff electricity) and circulated to radiator panels that heat the room.	\$5,000+	\$100-\$350 (natural gas)
Electric in-slab	A concrete slab is heated by internal electric cables (or hot water pipes).	\$3 per ft ²	\$100-\$1352
Electric thin-film	Thin films installed in the ceiling wall panels or under floor coverings to give radiant heat.	\$3.5 per ft ²	\$150-\$2203

Note 1: Heater use for the winter quarter (90 days), for 8 hours per day, in an average temperature of 8 - 18°C

Zoned Systems

Zoned systems are small space heaters designed to heat a zone, rather than a whole space. The space heaters are placed throughout the space, allowing you to adjust the temperatures in different area. These tend to be more economical than central forced air heating simply because the units are smaller with lower running costs and these allow greater flexibility and individual control.

Where space heaters are used, each unit will likely be individually controlled by its own thermostat, which is usually the basic type. This allows you to keep unused areas at a lower temperature than those areas you do use.

Electric baseboard heaters and radiant heating panels are examples of zoned heating.

Types of Zoned Space Heaters

The most economical space heaters in terms of running costs are either:

1. High efficiency (5-6 star rated) natural gas heaters;
2. High efficiency (3-6 star rated) reverse cycle air conditioners; or
3. Off-peak electric storage fan heaters

When choosing gas systems or reverse cycle zone air conditioners, look for the energy rating label - the more stars you see, the better the performance, and the more money you'll save on your energy bill.

The table below compares various space heaters per 600 sq-ft space.

Space Heating System(600 sq-ft)	Description	Approx. purchase & install price	Annual Heating Costs (note-1)
Natural gas space heater	Produces convective and radiant heat or a combination of the two. Can be mounted on external walls or internal walls where a vertical flue can be a fitted. Rated for energy efficiency.	\$600+	4-5 star rated: \$70 - \$125
Electric Storage fan heater(off-peak tariff)	Radiant/convection heaters which store off-peak electricity as heat in storage bricks. The fan helps distribute the heat and control the heat delivery and temperature.	\$500+	\$50 - \$90
Reverse-cycle air conditioner (4 - 5 star rated)	Heat pump electric convection heaters, which extract heat from the outside air and deliver it into the space. Use a compressor and fan. Can also provide cooling. Rated for energy efficiency.	\$800 - \$5,000	\$55 -\$120

Electric space heater (continuous tariff)	Convection or radiant heaters which use 'general rate' electricity. Can be expensive to run, so should be limited to heating for short periods only (e.g. bedrooms)	\$20+	\$160 - \$200
LPG space heater	Run on LPG. Produce convective and radiant heat or a combination of the two.	\$600+	\$100 - \$300
Slow combustion wood heater	Convection or radiant heaters burning wood. Efficiency and performance depends on quality of wood and method of operation.	\$800+	\$85 - \$110

Note 1: Heater use for the winter quarter (90 days), for 8 hours per day, in an average temperature of 8 to - 18°C

Central or Zoned System

The type that's best for you depends on the size of your facility, as well as the lifestyle. A central heating system heats all spaces served to the level required by those in use and is preferred for large facilities. In these cases, redundancy and backup capability is generally considered in the design. The overall efficiency of a central system at peak loading is generally high compared to multiple zone space heaters.

Zoned heating is a plus, if majority of areas remain unoccupied and if the people preferences require different temperatures or they disagree about the most comfortable temperature. Smaller commercial buildings typically use packaged split or roof top equipment sized with this capability in mind. Redundancy is not factored into the design. If a unit fails, the presumption is that it will be repaired or replaced in short order. Most zone space heating systems permit room by room control and during off-load periods; they afford significant energy and cost savings, particularly when spaces are used only on occasional basis. Time controls, personnel detection controls and other devices are normally integral to the unit.

As a general guideline, refer to the table below for a residential space:

If you need to heat....	Then.....
Only living zones	Use one or more high efficiency space heaters
Living areas for long periods, sleeping areas for short periods	Use high efficiency space heaters for living zones and electric 'spot' heaters for sleeping areas, or a zoned central heating system

Living and sleeping areas for long periods but at different times of the day	Use a zoned central heating system
Living and sleeping areas both for long periods at the same time	Use a zoned central heating system
Bathrooms/ensuites	Use radiant heaters, e.g. strip heaters, infra-red lamps

Hot water (hydronic) heating

A hot water heating system distributes hot water from a boiler to radiators, convectors or under-floor heating systems in each room. Modern systems feature smaller boilers, narrow piping and compact radiators that can be regulated to provide temperature control in each room. Under-floor heating systems can be built into the floors of new and existing homes.

The hot water circulation systems are particularly popular for large facilities such as residential complexes and commercial establishments, especially when viewed as one common system for domestic hot water supply and building heating system supply.

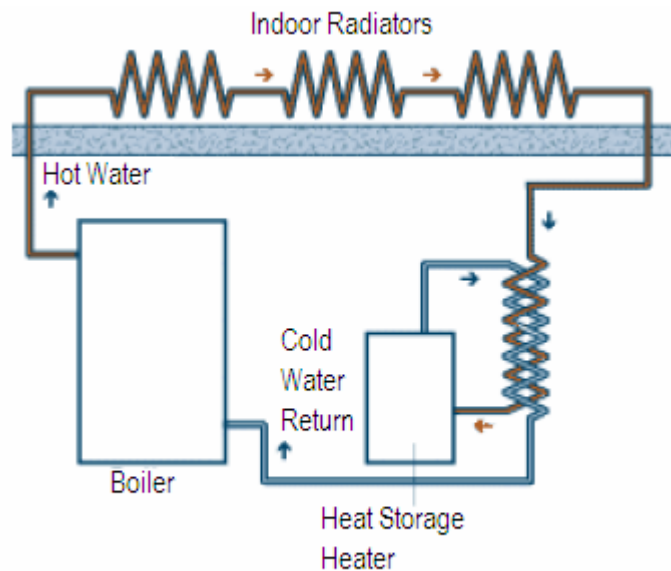

Hot Water Heating System

In the following sections we will discuss some design aspects of commercially installed Gas Fired Heating Systems, Hot Water Heating Systems and Electric Heating Systems in detail.

SECTION #4 GAS & OIL FIRED SPACE HEATING SYSTEMS

Gas fired heating systems normally offer the most cost effective way to heat large buildings. Gas or oil furnaces work on the same basic principle - the fuel is burned inside an enclosed metal container, generally referred to as a fire box, and the exhaust gases are vented to the exterior of the building. The combustion of the fuel warms the heat exchanger, which radiates the heat into the air in the living area. This heated air is circulated by gravity or pumped through the living area with a fan. Electric and oil fired heaters are sometimes useful for very specific space heating applications when gas is not available.

In this section, we will examine:

1. Codes & Standards
2. Classification of furnaces
3. Application considerations – forced air furnaces, unit heaters and radiant heaters
4. Combustion requirements and the factors affecting combustion efficiency
5. Combustion – air intake configurations
6. Venting – gravity vs. power venting
7. Gas heating furnace controls
8. Installations – Do's and Don'ts
9. Safety precautions
10. Installation, Operation and Maintenance guidelines

Codes & Standards

In US, installation of gas furnaces must conform to local building codes. In the absence of local codes, units must be installed according to the current National Fuel Gas Code (ANSI-Z223.1/NFPA 54). In Canada, installation must conform to current National Standard of Canada CSA-B149 Natural Gas and Propane Installation Codes, local plumbing or waste water codes and other applicable local codes. (Refer to annexure 1 for details).

Classification of Furnaces

The furnaces are classified by the way they transfer heat to the space. There are three ways in which gas fired heaters transfer their heat: direct fired heaters, indirect fired heaters and radiant heaters.

Direct-fired Heating Systems

Direct-fired air heating systems push air past an open flame and the products of combustion are delivered inside the building. There is no separation between the air to be heated and the combustion chamber and the space air is heated directly.

Because the heated air contains the combustion gases, this style of heater can only be used in well ventilated space and/or where large volumes of fresh outside air are admitted to the heated space as a normal part of the building's function. These have application in many places, such as paint booths, distribution centers, warehouses etc.

The efficiency of direct-fired systems tends to be higher than that for indirect fired systems because there are no duct losses and generally do not have casing losses. They also minimize flue losses because they are not vented to the outdoors. However, efficiency is limited to about 90% because buildings heated in this manner must be ventilated at the rate of 3.5 to 4.5 CFM for each 1000 BTUH input.

There are two types of direct fired air heating systems.

1. **Blow-thru Heaters** are essentially high temperature rise heaters, where the burner is located downstream of the blower. These heaters allow for the very high temperature rise to the tune of 160°F and therefore achieve the highest BTU/CFM ratio, which means lower horsepower motors, less outside air and reduced energy costs. These are well suited for large facilities such as warehouse or industrial facilities.
2. **Draw-thru heaters** are essentially low temperature rise heaters which use a draw-thru blower downstream from the burner. They move a large volume of warm air through a low temperature rise and provide constant air output. Generally these heaters are used as makeup air heaters for the facilities, which exhaust large volumes of air during the heating season.

As a rule of thumb, high temperature rise blow-thru designs are best suited for space heating, while low temperature rise draw-thru designs are best suited for heating makeup air.

Codes and Standards

It is important to perform a detailed codes and standards search when considering a design utilizing direct gas-fired heaters. There are two primary equipment standards and two primary codes that provide specific operating and application guidelines for direct gas-fired heaters:

1. ANSI Standard Z83.4, Non-Recirculating Direct Gas-Fired Industrial Air Heaters for 100-percent outside-air application includes limitations on combustion byproducts (CO less than 5.0 ppm, NO₂ less than 0.5 ppm, and CO₂ less than 4,000 ppm), gas-ignition control, combustion-air control, and flame safety.
2. ANSI Standard Z83.18, Recirculating Direct Gas-Fired Industrial Air Heaters for recirculating direct gas-fired heaters includes limitations on combustion byproducts (CO less than 25 ppm, NO₂ less than 3 ppm, and CO₂ less than 5,000 ppm), gas-ignition control, combustion-air control, and flame safety. The standard prescribes a limit on air-temperature rise based on the percentage of recirculated air.
3. International Fuel Gas Code. The International Fuel Gas Code has separate sections to address non-recirculating direct-fired AHUs (Section 611) and recirculating direct-fired AHUs (Section 612). Both sections note that direct-fired heaters cannot supply any area with sleeping quarters, makeup air must come from outside, motorized outside-air dampers/louvers must be proven open prior to burner activation, systems must be controlled properly to prevent building over-pressurization, and burner controls need to have a burner purge cycle.
4. NFPA Standard 54, National Fuel Gas Code. NFPA Standard 54 has similar requirements as sections 611 and 612 of the International Fuel Gas Code. Its requirements differ depending on whether a direct-fired heater is listed (Edison, UL) or unlisted. Unlisted direct-fired AHU discharge-air temperature is limited to 150°F.

Note that the codes are the mandatory requirements while standard are voluntary.

Indirect-fired Heating System

An indirect fired space heater is a very different machine than direct fired system. An indirect gas-fired heater has a sealed combustion chamber in which all products of combustion are discharged through a flue to the outside environment and no products of combustion are discharged within the makeup air supplied to the building. This arrangement is called indirect because there is no direct contact between the flame and the heated inside room air.

These styles of heaters are frequently utilized for recirculating air applications and are very effective in spaces which need to be heated quickly and which contain a strong presence of people. Most heating systems in occupied areas are indirect fired and the two systems are shown in the schematic below:

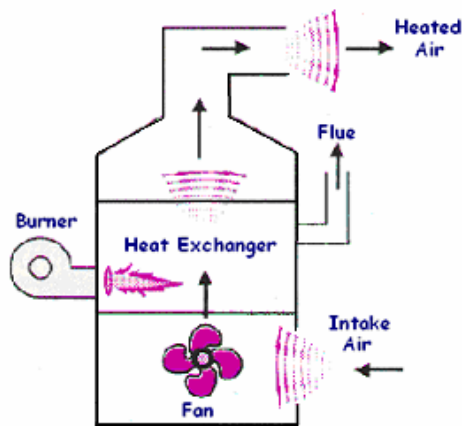

Floor mounted Convection Heater

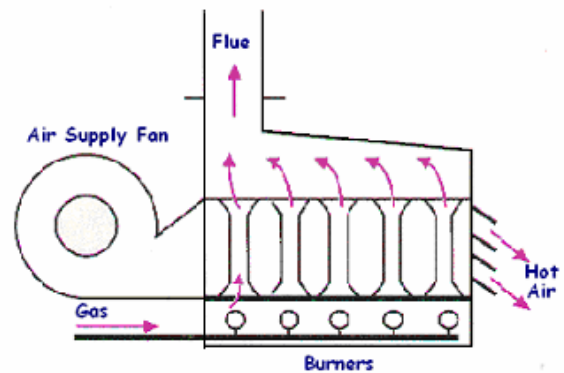

Roof mounted Convection Heater

Indirect-fired duct-furnace system efficiencies are lower due to duct heat losses (heat lost from warm-air ducts to the unheated spaces through which the ducts may be directed), casing losses (heat lost from the heater to the space surrounding the heater), flue loss (heat lost through walls and ceilings due to movement of heated air).

Indirect fired heaters are available in two configurations: 1) Up-flow arrangement and 2) Down-flow arrangement.

When a furnace is installed in a basement it is considered an "Up flow" furnace, meaning the cooler air is drawn at the base of the furnace, and the warm air exits out the top of the furnace.

If a furnace is installed on the main floor of a space and the heat comes from floor registers, it is a "Down flow" furnace. In a down flow furnace, the cool air enters the furnace at the top and the warmed air exits at the bottom.

Radiant Fired Heaters

In a radiant gas-fired heater, the flame is used to heat a surface which in turn emits heat in the form of rays. The materials used in this process can withstand extremely high temperatures. Radiant heaters have very good system efficiencies for the following reasons:

1. Radiant heaters do not heat the air; they heat the objects in the space by radiation. Occupants can be comfortable at a lower air temperature; where a lower air temperature means lower losses through the building's walls;

2. Radiant heaters require no forced air circulation, minimizing convection losses through the building's walls;
3. Radiant heaters normally are unvented but buildings must be ventilated at the rate of 3.5 to 4.5 CFM for each 1000 BTUH input. Such ventilation is usually accomplished with powered exhausters installed at the highest point of the roof.

Radiant gas-fired heaters are fast and efficient and can be used conveniently in industrial processes like the drying of paper, paint, and textiles as well as space heating.

Application and Equipment Considerations

In addition to being categorized by their method of heat transfer (indirect-fired, direct-fired and radiant), heaters are categorized according to their construction features. Forced-air heaters fall into two broad category: 1) Duct furnaces and 2) Unit heaters.

Forced Air Ducted Furnaces

1. **Conventional natural gas-fired furnaces** - This system consists of a furnace with a naturally aspirating gas burner, which means that air for combustion is drawn in from the surrounding area by the natural forces of hot air rising. The combustion gases pass through the furnace where they give up heat across a heat exchanger and are exhausted to the outside through a flue pipe and vent. A dilution device, known as draft hood serves to isolate the burner from outside pressure fluctuations at the vent exit by pulling varying quantities of heated space air into the exhaust as required. A circulating fan passes cooled space air from the return ducts over the furnace heat exchanger, where the air is warmed up and passed into the ductwork for distribution around the indoor space.

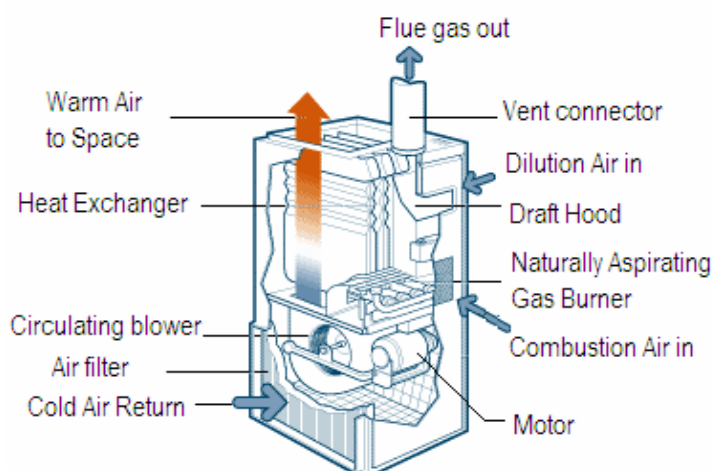

Conventional Gas Furnace

Note that there are two entirely separate air movement paths: first, the combustion path supplies air to the burner and to the draft hood and carries hot combustion gases through the burner, heat exchanger and flue pipe to the vent outdoors and second, the heat distribution and cold air return path circulates and heats the air indoors.

These systems usually have seasonal efficiencies of about 60%. A minor improvement in efficiency comes with adding a vent damper in the flue exhaust. By closing off the vent during the off cycle, the damper prevents some of the warm air from being drawn up the flue and lost to the outdoors.

These furnaces usually have an electric or electronic ignition. Older units were equipped with a standing (continuously lit) pilot light; the newer ones feature electric ignition. Fuel savings are generally in the 3-9% range, relative to a conventional furnace.

2. **Conventional oil furnaces** – This is similar to a natural gas furnace, but the dilution device is a barometric damper; a plate that acts as a valve on the side of the flue pipe. The damper isolates the burner from changes in pressure at the chimney exit by pulling varying quantities of heated room air into the exhaust. The quantity of air drawn through the barometric damper is much greater than the quantity required for combustion and can represent 10% to 15% of the total heat loss. The burner is a high-pressure gun type, with a blower fan to help mix the oil and air for good combustion. A conventional oil furnace with a cast-iron head burner has a seasonal efficiency about 60%. Replacing the conventional burner with a flame retention head burner will save 10-15% on the fuel bill.
3. **Mid-efficiency gas furnaces** - Mid-efficiency gas furnaces mainly use a naturally aspirating burner and do not have a continuously lit pilot light. They are equipped with a powered exhaust, usually with a built-in induced draft fan, and they do not have a draft hood. With more heat exchange, no dilution air, and high resistance to flow during the off cycle, seasonal efficiency is much higher for mid-efficiency gas furnaces than for conventional furnaces, offering energy savings of 15 to 25 percent over conventional gas furnaces. These systems can be vented through a properly sized chimney or out the side wall of the house using high-grade stainless steel.

One word of caution: do not buy a mid-efficiency furnace that is more than 82% efficient. These systems often have condensation problems in the furnace or venting system. There is also some concern about the longevity of the high

temperature plastic pipe used to vent many of these mid-efficiency units. For higher efficiency, get a condensing furnace.

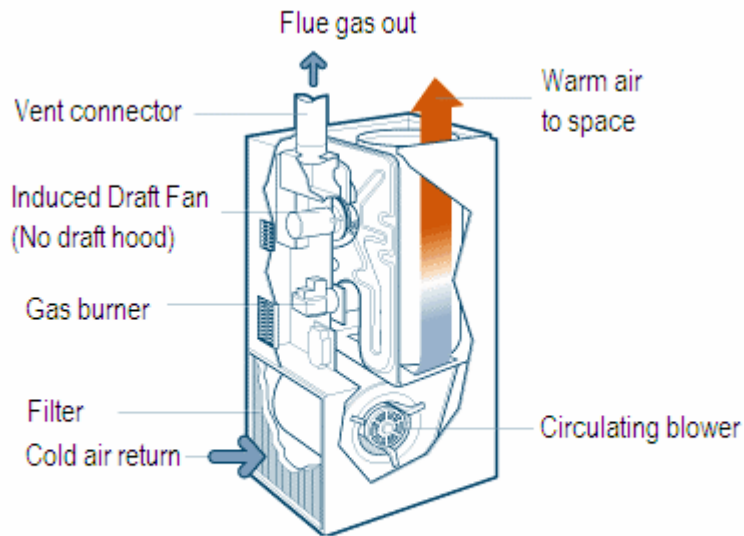

Mid Efficiency Gas Furnace

4. **Mid-efficiency oil furnaces** use a more efficient high-static retention burner. This type of furnace also features an improved low-mass combustion chamber (usually ceramic fiber) and passes the hot combustion gases through a superior heat exchanger that enables the circulating space air to extract more heat. The barometric damper, with its large requirement for air to dilute the combustion gases, has been eliminated in the most efficient of these designs. Benefits of a good mid-efficiency furnace are much lower combustion and dilution air requirements as well as more power to exhaust the combustion products (both advantages in new, tighter housing); a safety shutoff in case of draft problems; and a more effective venting system. Mid-efficiency oil furnaces can have seasonal efficiencies of 85-89% and use 25-30% less fuel than a conventional oil furnace producing the same amount of heat.
5. **High Efficiency Condensing Gas Furnaces** – These are the most efficient furnaces available, with seasonal efficiencies between 89 and 97 percent. Most have burners similar to conventional furnaces, with draft supplied by an induced draft fan. There are additional (or enlarged) heat exchange surfaces made of corrosion-resistant materials (usually stainless steel) that extract most of the heat remaining in the combustion byproducts before they are exhausted. Because of increased heat transfer, the exhaust gases temperature drops to the dew point of the water vapor, causing the vapor to condense and give up 970 BTU for every

pound of water condensed. Natural gas can yield more than 1 gallon (8 lbs) of water per 100,000 BTU (one therm) burned, giving up about 7,760 BTU. The condensate is piped to a floor drain.

A chimney is not needed and energy efficiency is further increased. Because the flue gas temperature is low, plastic piping can be used for venting out the side wall of the building. Although a condensing unit costs more than a non-condensing unit, the condensing unit can save you fuel up to 40%. Furthermore, polluting emissions released into the environment are also reduced.

A second type of condensing furnace uses a pulse combustion principle. The technology relies on igniting small amounts of gas at frequent intervals; otherwise, it is essentially similar to the previously described condensing furnace.

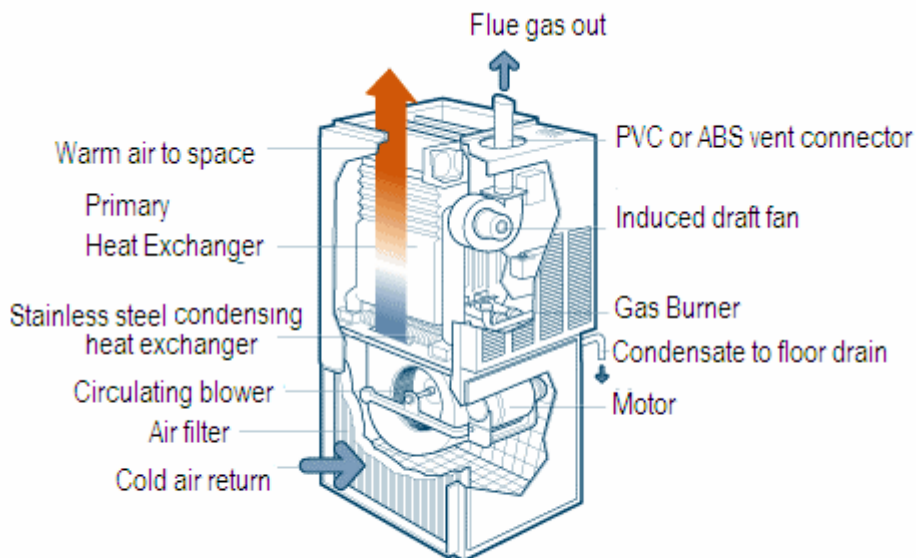

High Efficiency Condensing Gas Furnace

6. **Condensing Oil Furnaces:** While a natural-gas condensing furnace has a significant efficiency advantage over a mid-efficiency gas furnace, a “condensing oil furnace” is only marginally more efficient than a well-designed mid-efficiency oil furnace. Oil produces only half the water vapor of gas, and so has much less energy tied up in the form of latent heat; the furnace must work harder to condense less. In addition, the condensate is much more corrosive than with natural gas, so the condensing oil heat exchanger must be made of special materials. For these reasons, a mid-efficiency oil furnace is a better bet than a condensing oil furnace.

UNIT HEATERS

Unit heaters are compact, completely self-contained, normally non-duct indirect-fired systems, which eliminate duct and casing losses and therefore, their system efficiency is somewhat higher. Some unit heaters can also be suitable for ducted air circulation.

Unit heaters are excellent for areas where a concentrated heat source is desired and are generally mounted near the ceiling. Multiple heaters can be placed in larger space, allowing you to adjust the temperatures in different areas. These are often installed around the perimeter of a building.

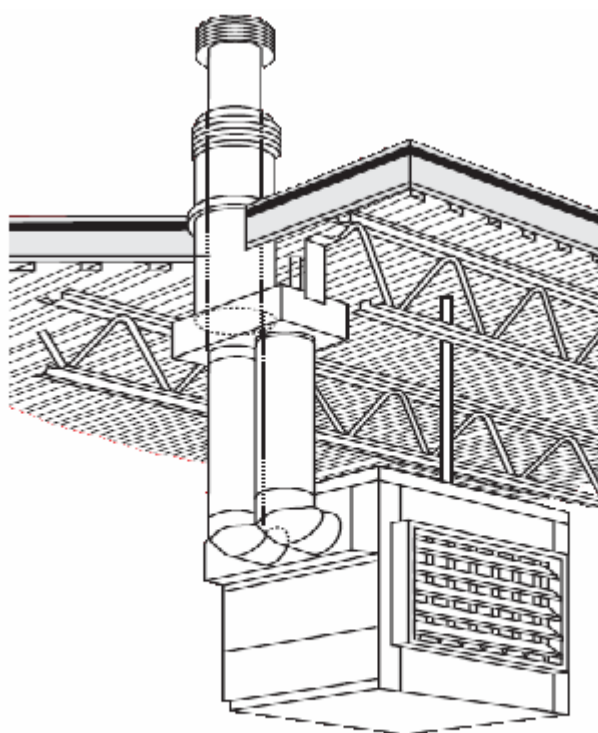

Ceiling mounted Unit Heater

Advantages include:

- Tend to be more economical than central forced air heating simply because the units are smaller with lower running costs;
- Allow for greater flexibility and individual control;
- Redundancy in case one unit fails and intermittent fan operation that reduces electrical costs;
- Can be installed near the ceiling to get more floor space but due to limited air throw, their efficiency decreases with increasing height above the floor.

Unit heaters are available with either fan-powered or blower-powered recirculated air movers. Fans deliver air at large flow rates against low resistance. Blowers are used in high static systems to distribute air through ductwork where resistance is high and lower volumes are required or to “throw” heated air a considerable distance in a ductless system. Most unit heaters employ a propeller fan, which is cycled on and off in a sequence related to the on-and-off cycling of the burner.

A wide range of facilities, such as factories, garages, storerooms, supermarkets, gymnasiums, swimming-pool enclosures and auto showrooms, can be heated for occupant comfort with unit heaters.

Measure of Efficiency for Furnaces

The efficiency of a gas furnace is measured by the Annual Fuel Utilization Efficiency (AFUE), a rating that takes into consideration losses from pilot lights, start-up and stopping. The minimum AFUE for most furnaces is now 78%, with efficiencies ranging up to 97% for furnaces with condensing heat exchangers. The AFUE does not consider the unit’s electricity use for fans and blowers, which can easily exceed \$50 annually. An AFUE rating of 78% means that for every \$1.00 worth of fuel used by the unit, approximately \$.78 worth of usable heat is produced. The remaining \$.22 worth of energy is lost as waste heat and exhausted up the flue. Efficiency is highest, if the furnace operates for longer periods. Oversized units run intermittently and have reduced operating efficiencies.

Furnaces with AFUEs of 78% to 87% include components such as electronic ignitions, efficient heat exchangers, better intake air controls, and induced draft blowers to exhaust combustion products.

Furnaces are often classified as standard, mid and high efficient units. A standard furnace is one whose efficiency is below 70%, a mid efficient furnace is one whose efficiency is between 71% and 82%, and a high efficient condensing furnace is one with efficiency above 90%.

Combustion Efficiency

In order to understand the basics of combustion efficiency, the combustion process must be understood. Stable combustion conditions require three inputs: fuel, oxygen and a source of ignition. If the combustibles themselves can provide this third element as they burn, the source of ignition can be turned off. The products of complete combustion are heat energy, carbon dioxide, water vapor, nitrogen and other gases (excluding oxygen).

Complete combustion takes place when there are enough oxygen atoms to match up with all the carbon and hydrogen atoms present. Three important facts need to be remembered for ensuring complete combustion:

1. Burning fuel gas completely produces only harmless carbon dioxide, water vapor; nitrogen and other gases (excluding oxygen);
2. A definite amount of fuel requires a definite amount of oxygen for complete combustion; and
3. Definite amounts of combustion products are formed in burning a fuel gas completely.

When an insufficient amount of air is supplied to the burners, the result is dangerous and costly incomplete combustion. Incomplete combustion will result in formation of carbon monoxide; a poisonous gas that can cause death when breathed. Carbon monoxide can be particularly dangerous because it has no odor, color or taste and has increasingly serious effects at increasing concentrations and exposure times. Incomplete combustion is also costly because not all the heat available in the fuel is released when carbon monoxide is formed, so there is a waste of fuel resulting in inefficiency and the potential for an explosion.

To avoid these costly and unsafe conditions, furnaces are normally operated at an "excess air"; the amount of air over and above the theoretical requirement. This excess air level also provides operating protection from an insufficient oxygen condition caused by variations in fuel composition and "operating slop" in the fuel-air control system. Typical optimum values of excess air levels (and equivalent percentage of oxygen by volume) are shown in the table below:

Typical Optimum Excess Air Levels			
Fuel Type	Firing Method	Optimum Excess Air	Equivalent Percent O ₂ (by Volume)
Natural Gas	-	5%- 10%	1% - 2%
Propane	-	5%- 10%	1% - 2%
Coke Oven Gas	-	5%- 10%	1% - 2%

No #2 Oil	Steam atomized	10%- 15%	2% - 3%
No #6 Oil	Steam atomized	10%- 15%	2% - 3.5%

It is important to understand that "excess air" and "excess oxygen" is not the same. Because air is roughly 21% oxygen by volume, 50% excess air is approximately equal to 10.5% oxygen remaining in the exhaust stack.

While insufficient air to the burners can be dangerous, airflows in excess of those needed for stable flame propagation needlessly increase flue gas heat losses and consequently lower efficiency. Minimizing these losses requires monitoring for two variables: the percentage of O₂ (or CO₂), and the stack temperature. *Very high percent of O₂ in the flue stack means lower efficiency.* The percentage of O₂ (or CO₂) can be measured by using simple devices containing gas-absorbing analyzers.

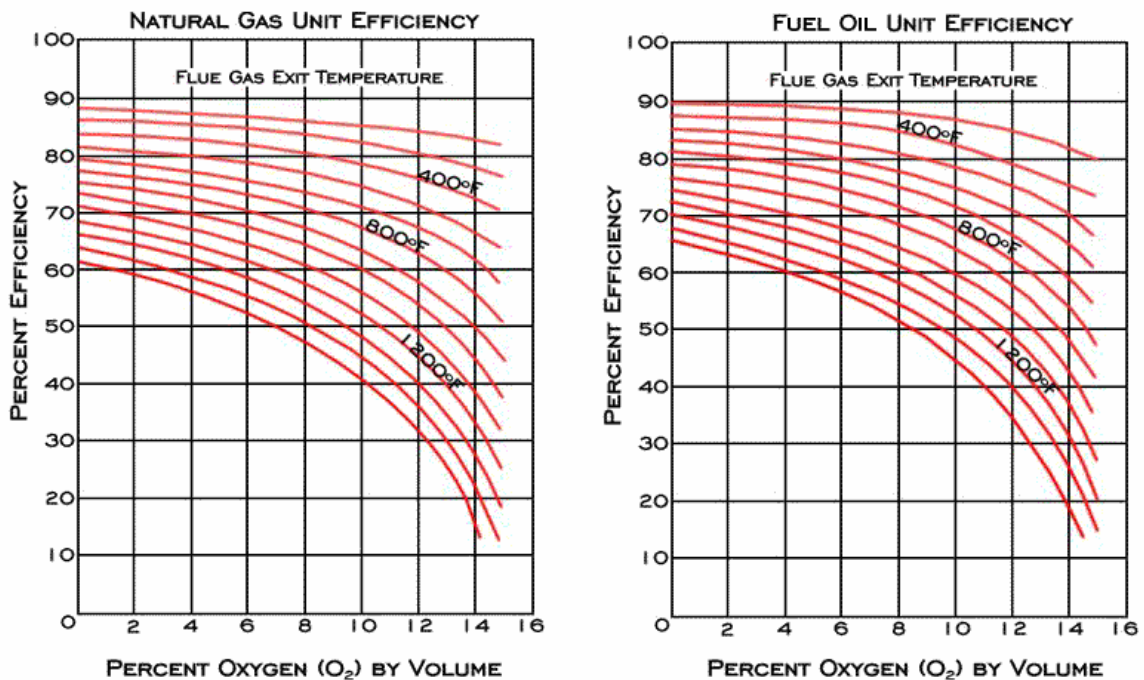

These figures show the relationship between proper tune-up, proper heat transfer and efficiency.

As fuel is such a dominant cost factor, the boiler efficiency needs to be kept high to keep operating costs low. Decreases in efficiency over time can indicate the need for minor adjustments or repairs. In some cases, only control linkages, a fuel valve, or an air damper may need to be adjusted. In other cases, a worn burner tip or control cam may

need replacing. High stack temperatures may also indicate the need for cleaning. In any situation, decreases in efficiency indicate the need for professional maintenance.

Controlled and Explosive Combustion

Since complete combustion is necessary for both safety and economy in space heating, it is important to supply air and fuel gas to heating devices in the proper amounts and at proper rates to ensure complete burning of the gas in a steady controlled flame.

Explosive combustion can result when an air-gas mixture does not ignite the instant it leaves the burner. The air-gas mixture may then collect in the combustion chamber and burn almost instantaneously (explode). The gas burners of heaters and furnaces are designed and equipped for safe and economical controlled combustion, when they are correctly adjusted and operated.

Combustion and Vent Techniques

Most furnaces use the surrounding air for combustion and others bring combustion air directly into the combustion chamber through sealed plastic piping that extends to outside air. Typical commercial terminology on the way furnaces take combustion air and exhaust flue gases are:

1. **Direct Vent or Sealed installations** - Combustion air is taken from outdoors and flue gases are discharged outdoors. Direct vent furnaces can be installed within the conditioned area of a living space since they do not rely on inside air for safe operation.
2. **Non-Direct Vent installations** - Combustion air is taken from indoors and flue gases are discharged outdoors. Non-direct vent furnaces must receive adequate outside air for combustion and exhaust venting. The primary concern with non-direct vent units is that a malfunctioning heater may allow flue gases inside.
3. **Un-vented installations** - Combustion air is taken from indoors and the flue products are discharged into the space. In unvented installations, the products of combustion: carbon dioxide (CO₂), water (H₂O), and carbon monoxide (CO) are discharged into the space. These heaters should be used only in areas where adequate ventilation is available. All unvented gas-fired space heaters should be equipped with an oxygen depletion sensor (ODS). An ODS detects a reduced level of oxygen in the area where the heater is operating and shuts off the heater before a hazardous level of carbon monoxide accumulates. These heaters also have labels that warn users about the hazards of carbon monoxide. Always have

your gas heater and venting system professionally installed and inspected according to local codes.

Ventilation Air Configurations

Unless outside air is brought into the space for combustion, negative pressure will build to the point that a downdraft can occur in the furnace vent pipe or chimney. As a result, combustion gases enter the living space creating a potentially dangerous situation. The requirements for providing air for combustion and ventilation depend largely on whether the furnace is installed in an unconfined or a confined space.

Confined Spaces:

A confined space is a space having volume less than 50 cubic feet per 1,000 BTUH of the combined input rating of all appliances installed in that space. This definition includes furnace closets or small equipment rooms. The confined space must have two permanent openings to permit outside air. Two air intake configurations are as follows:

- 1) **Air from Inside:** If the confined space that houses the furnace adjoins a space categorized as unconfined, the air can be brought in by providing two permanent openings between the two spaces. Each opening must have a minimum free area of 1 square inch per 1,000 BTUH of total input rating of all gas-fired equipment but not less than 100 square inches for each opening. One opening shall be within 12 inches of the top of the enclosure and the other within 12 inches of the bottom.

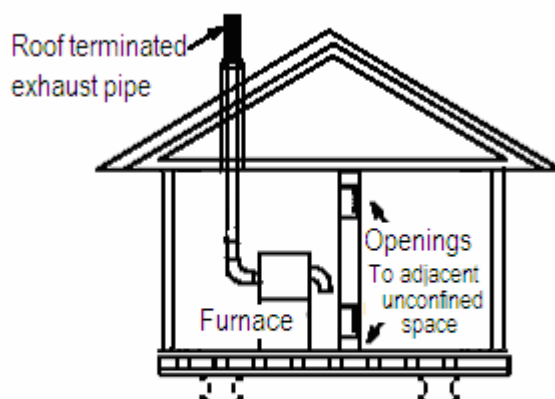

Equipment in Confined Space
(All air from inside)

- 2) **Air from Outside:** If air from outside is brought in for combustion and ventilation, the confined space shall be provided with two permanent openings. One opening shall be within 12 inches of the top of the enclosure and one within 12 inches of the

bottom. These openings must communicate directly or via ducts with the outdoors or spaces (crawl or attic) that freely communicate with the outdoors or indirectly through vertical ducts. Each opening shall have a minimum free area of 1 square inch per 4,000 BTUH of total input rating of all equipment in the enclosure. When communicating with the outdoors through horizontal ducts, each opening shall have a minimum free area of 1 square inch per 2,000 BTU per total input rating of all equipment in the enclosure. Refer to the figures below:

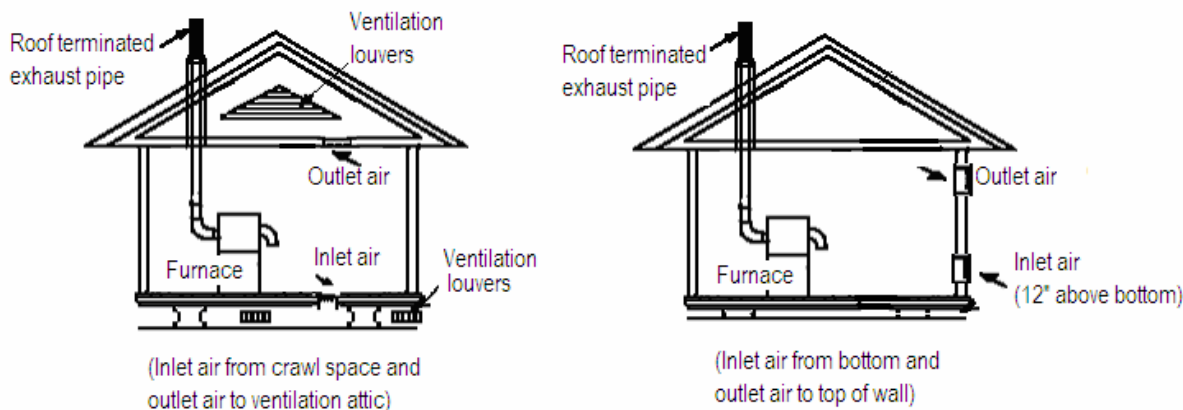

Equipment in Confined Space (All air from outside)

Other special requirements

- When ducts are used, they shall be of the same cross-sectional area as the free area of the openings to which they connect. The minimum dimension of rectangular air ducts shall be no less than 3 inches.
- If mechanical combustion air fans are used, provide 15 to 20 cu-ft of combustion air for each 1000 BTU burned.
- In calculating the free area, the blocking effect of louvers, grilles, or screens must be considered. Metal louvers normally provide 60% free space. Example: A 20" by 20" louver would have a free area of 240 sq-in (20 x 20 x .60). Wooden louvers will have 20 to 25 percent free area. Louvers and grilles must be fixed in the open position or interlocked with the equipment so that they are opened automatically during equipment operation.

Unconfined Spaces:

An unconfined space is defined as a space having volume greater than 50 cubic feet per 1,000 BTUH of the combined input rating of all appliances installed in that space. Such areas may include a basement or large equipment rooms.

There is no special requirement for bringing outside air for unconfined spaces but when a building's construction includes extensive insulation, vapor barriers, tight fitting and gasketed windows and doors, and weather stripping, the introduction of outside air through properly sized wall openings and ducts may become necessary to make sure that under all conditions, there will not be a negative pressure within the equipment room. Follow the same air intake procedures for bringing outside air as for the confined spaces discussed above.

Exhaust Air Vent System Configurations

Modern indirect-fired equipment is designed to operate safely and efficiently with single-wall vent pipe in runs 5 feet to 50 feet long. Double-wall pipe is often substituted for single-wall pipe if required by local standards.

For power-vented heating equipment, the vent pipe can run vertically or horizontally. Horizontal vent pipe allows less room heat to escape through the flue than vertical pipe, thereby saving fuel.

Gravity-vented equipment must have vertical venting, but may have horizontal runs that must not exceed 75% of the vertical flue height dimension.

The heating-equipment manufacturer's venting directions should be followed closely as to terminal arrangement, pipe size, pipe connections, pipe support, etc.

All pipes must be sealed to prevent leakage of flue gas. Aluminum or Teflon tape rated 550°F service is recommended.

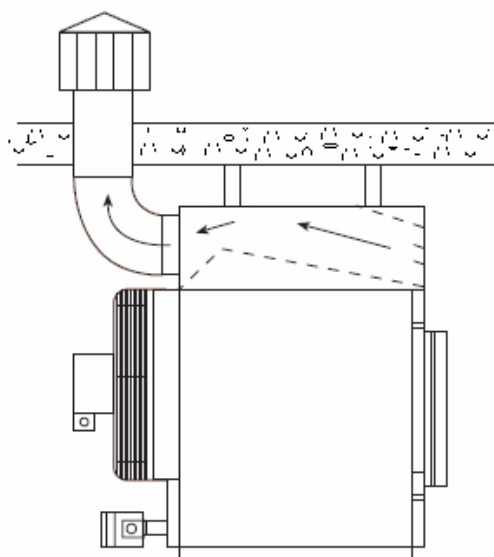

Gravity Vented

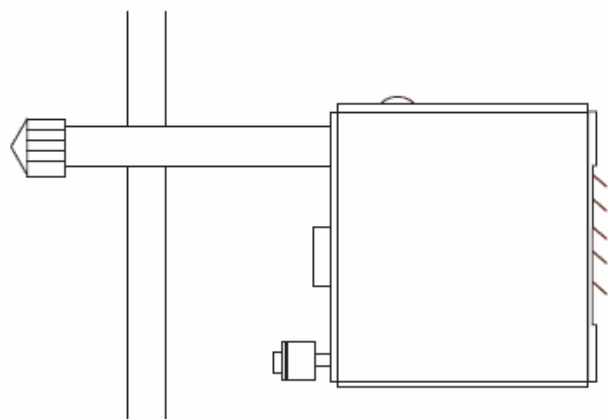

Power Vented

Rules for Gravity Vents

There are several rules to follow to assure proper venting of gravity vented equipment:

1. Keep vent runs as straight as possible with few turns or bends.
2. Never use a vent size smaller than the size recommended by the equipment manufacturer.
3. All vents must terminate with a proper wind proof vent cap.
4. Limit horizontal vent runs to a maximum of 75% of the vertical run. Example, if the vertical run is 10 ft, the horizontal run must not exceed 7.5 ft.
5. Horizontal runs must be pitched with a minimum upward slope of .25 inch per foot of run.
6. Vents must terminate a minimum of 2.5 ft above any obstructions within a 10 ft radius of the vent pipe.
7. Always provide a drip leg as near to the equipment as possible. This to prevent condensation of flue gases in the vent pipe from entering the equipment.
8. Keep combustible material 6 inches away from single wall vent pipe
9. *When venting into a common vent, the area of the common vent should be equal to or greater than the area of the largest vent plus 50% of the area of all additional vents.*
10. When venting into a common vent, the individual vents should enter at different levels.

Rules for Power Vents

The rules for power vented equipment generally are the same as gravity vented equipment with the following exceptions:

1. Approved power exhausted equipment may have its vent system terminate horizontally out of a wall. A proper vent cap must still be installed.
2. Horizontal run lengths may exceed vertical run lengths. The combined total run length must not exceed the manufacturer's recommendations.
3. If elbows are used in the vent system, you must attribute 6 ft. of equivalent length of run for each 90 degree elbow.
4. If a vent terminates horizontally out of a wall, make sure it does not terminate near an air inlet opening. A minimum of 3 ft. is recommended.

5. Make sure the horizontal vents are sufficiently high enough, or guarded so as to prevent accidental contact by people or equipment.
6. No common venting should be utilized.

Gas Heating Furnace Controls

Duct furnaces may be equipped with any of several gas-control systems:

1. **Single-stage control:** A single stage control is simply on or off, i.e. the gas valve provides full fire on a call for heat.
2. **Two-stage control for heating applications:** A two-stage control was developed with comfort in mind. Here is how it functions: When the thermostat activates the furnace, it comes on at 2/3rd the strength (burning gas at 65% of maximum). If, after 10 minutes of operation, the thermostat is still calling for heat, the furnace will switch to 100%. What that accomplishes is a uniform heating of the entire space. If a furnace kicks on at full power and dumps hot air into the space to satisfy the thermostat, it will shut off leaving cool air still circulating the space, i.e. the furnace will have to kick in again. Two-stage furnaces are more efficient and more effective at heating the space. Furnaces are like light bulbs; they operate better if they are turned on and left on. If you flick a light switch on and off, and over and over, that bulb is toast. The same goes for furnaces. Running at 65% for 9 minutes is better than 100% for 3 minutes several times an hour. A two-stage furnace uses less gas and is easier on the machine.
3. **Two-Stage Variable:** Two-stage variable control was developed with the knowledge that subtle circulation of heated air is the most effective way to heat a space. The furnace part is the same as a two-stage; the difference is in the blower motor. In a single-stage, if you want your fan on for circulation, that fan is on high. It is the only option it has. Not only is that hard on the utility bill, but a fan on high means the warm air is moving fast as a cool breeze. In a variable mode, the fan turns over slowly to maintain air circulation while being easy on the utility bill. By the way, most air cleaners and filtration devices are only active when the furnace blower is on. So the best way to utilize these accessories is to have a variable speed blower. By switching its blower fan from AC current to DC current, it only draws 1/10th the electricity.
4. **Electronically Modulated Control** – Uses solid-state circuitry that smoothly varies the gas input between 50% and 100% of the unit's rated capacity, as

required by a call for heat from a wall-mounted room sensor. Such systems may or may not be certified for use with propane gas.

NOTE: Electronic modulation is available for both direct-fired and indirect fired equipment. Check the manufacturer's specifications for availability with certain gaseous fuels.

5. **Mechanically Modulated Control** – Uses a nonelectric, capillary-actuated system which smoothly varies the gas manifold pressure between 50% and 100% firing as required on a call from a thermostatic sensor. This system cannot be used on power-vented equipment unless the air mover is operated continuously.

Unit Heater Controls

In unit heater applications, individual room thermostats for ON-OFF operation provide an adequate and simple means of control. Unit heaters are available with summer/winter switches to permit fan operation without burner operation during warm weather when only air circulation is desired.

Pilot-ignition control systems - Unit heaters contain one of the following types of ignition systems:

- Manual match-lit gas pilot with 100% shut off;
- Spark-ignited intermittent gas pilot;
- Spark-ignited gas pilot with timed lockout;
- Direct spark whereby an electrical spark ignites the main burner;
- Hot surface ignited gas pilot; and
- Hot surface ignited main burner.

Gas-control Systems - Unit heater gas-control systems may contain a single-stage gas valve (which provides full fire on a call for heat) or a two-stage valve (which fires at either 100% or approximately 50% as required by a remote two-stage thermostat).

Installation – Do's and Don'ts

1. The furnace may be installed in alcoves, closets, attics, basements, garages, and utility rooms in the up-flow position. When a furnace is installed in an attic, the passageway to and service area surrounding the equipment shall be floored.
2. When the furnaces are installed in an attic or other insulated space, keep insulation away from the furnace.

3. For installation in a residential garage, the furnace must be installed so that the burner(s) and the ignition source are located no less than 18 inches above the floor. The furnace must be located or protected to avoid physical damage by vehicles.
4. The furnace shall not be installed directly on carpeting, tile, or other combustible material other than wood flooring.
5. Place the furnace as close to the center of the air distribution system as possible. The furnace should also be located close to the chimney or vent termination point.
6. When the furnace is installed in non-direct vent applications, do not block the furnace combustion air opening with clothing, boxes, doors, etc. Air is needed for proper combustion and safe unit operation.
7. When the furnace is installed in an unconditioned space, consider provisions required to prevent freezing of condensate drain system.
8. When this furnace is used with cooling units, it shall be installed in parallel with, or on the upstream side of cooling units to avoid condensation in the heating compartment.
9. The furnace must be installed so that its electrical components are protected from water. The furnace must be electrically grounded according to the current National Electric Code, ANSI/NFPA No. 70.

Always refer to local codes and guidelines of authorities having jurisdiction before installation.

SAFETY PRECAUTIONS

1. Gas-fired appliances are not designed for use in hazardous atmospheres containing flammable vapors, combustible dust or chlorinated or halogenated hydrocarbons.
2. All components of a gas supply system must be leak tested prior to placing equipment in service.
3. For best operation, gravity vented outdoor heaters should be located on the roof or slab with at least a 20-foot radius between the center of the vent cap and the obstructions such as walls, parapets or cupolas.
4. Failure to provide proper venting could result in death, serious injury, and/or property damage. The unit must be installed with a flue connection and proper

vent to the outside of the building. Follow installation codes and venting recommendations in the installation manual for this heater. Safe operation of any gravity-vented gas equipment requires a properly operating vent system, correct provision for combustion air and regular maintenance and inspection.

5. The use and storage of gasoline or other flammable vapors and liquids in open containers in the vicinity of this appliance is hazardous.
6. Joints where flue ducts attach to the furnace must be sealed securely to prevent air leakage into the draft hood or burner rack area. Leakage can cause poor combustion, pilot problems, shortened heat exchanger life, and can cause poor performance.
7. Make sure the thermostat has an adequate volt-ampere rating for the total load to be placed on it. Add up the amperage ratings of all relay coils, valve-solenoid coils or valve hot-wire coils, etc., and match the thermostat rating to the total.
8. The appliance is equipped for a maximum gas supply pressure of 1/2 pound, 8 ounces or 14 inches water column. NOTE: supply pressure higher than 1/2 pound require installation of an additional service regulator external to the unit.
9. The appliance must be isolated from the gas supply piping system by closing its individual shutoff valve during any pressure testing of the gas supply piping system at a test pressure equal to or more than 1/2 PSIG (3.45 KPa).
10. Due to the high voltage on the pilot spark wire and pilot electrode, do not touch when energized.
11. The operating valve is the prime safety shutoff. All gas supply lines must be free of dirt or scale before connecting the unit to ensure positive closure.

Operation and Maintenance Guidelines

During the later part of the summer it is time to start up the heating system. This is the time to make some routine checks which are necessary to ensure that your heating equipment will be ready to function properly in the fall and winter.

1. Check equipment for physical damage. Check the sheet metal, fans and air movers, wiring, fuel piping and vent system.
2. Check for the cleanliness of the equipment's heat exchanger and burner.
3. Check the vent system; sometimes birds will make nests in the vent system.
4. Check to make sure no obstructions block the air intake or air discharge of the equipment.

5. Check lubrication of the motors on fans and pumps. With the power off check to see that the motor shafts turns freely.
6. Check the belt tension on the equipment that utilizes a centrifugal blower system.
7. Check the heat exchanger of the equipment for any signs of cracks or corrosion. A flash light can be useful to check the inside and outside of the heat exchanger.
8. Check the heat exchanger of the equipment for signs of overheating. Metal that has been overheated will have a dark discoloring of the overheated area. Overheating could be the result of over-firing, improper venting, or inadequate combustion air.
9. Inspect the burner for general cleanliness. It is not uncommon to find that spiders or mice have nested in the control or burner area.
10. Check the control wiring to make sure the connections are tight.
11. Check to make sure the manual valves are opened.
12. If your space has an alarm system, make sure it is operational.

It is recommended that a record be kept of the date the heating equipment service was performed. It is also recommended that these same service checks be performed on a periodic basis throughout the heating season. By keeping a service record and updating it, it is less likely that this important maintenance will be overlooked.

SECTION #5 HOT WATER HEATING SYSTEMS

Hot water heating (sometimes called hydronic heating) systems use water or a water-based solution as a medium to transport heat from a heat source to one or several heat emitters. The hot water then radiates heat and warms the air within the space. As the water circulates it begins to cool and is then circulated back to a boiler for reheating.

These systems are useful as centralized heating systems in large building complexes and can be designed as forced air or radiant heating systems.

- In a forced air application the heated water is passed through a coil (much like an automobile radiator) and a blower pushes (or pulls) the cool air across the coil. At the coil, the air picks up the heat energy and the warm air is directed to the living area.
- In radiant systems the heated water is run through pipes in the floor (or walls) and the floor gets warm and the heat radiates into the living area.

In this section we will examine:

1. What is hydronic heating?
2. Why hydronic heating?
3. Gravity circulation vs. forced circulation
4. Heat transfer to space – terminal units
5. Hot water system design – primary elements:
 - Sizing distribution system
 - Estimating water flow rate
 - Sizing supply piping
 - Piping configuration – direct vs. reverse return system
 - Sizing the circulator
6. Secondary components such as expansion tanks, safety devices, instrumentation controls
7. Radiant floor heating system design

What is Hydronic heating?

Hydronic heating systems use hot water to move heat from where it is produced to where it is needed. Heat is absorbed by the water at a heat source, conveyed by the

water through the distribution piping, and finally released into a heated space by room heat emitters (Refer to Fig.1 below). Hundreds of system configurations are possible, each capable of meeting the exact comfort requirements. For example, it is common for hydronic radiant heating to be used on the first floor of a house while the second floor rooms are heated using panel radiators or fin-tube baseboard. All these equipment do not use ducting.

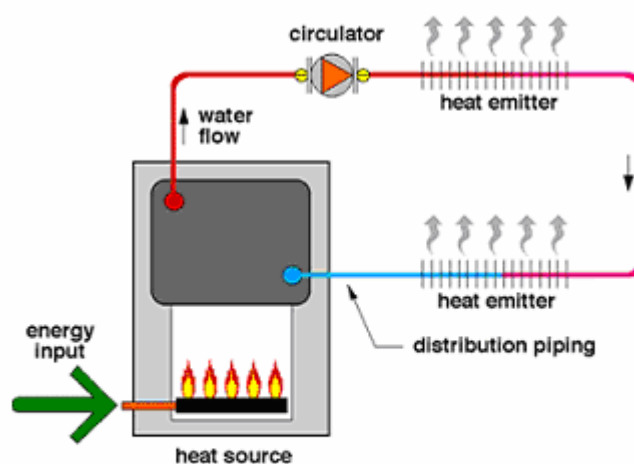

Fig - 1
Hydronic Heating with Room Emitters

Alternatively, a hydronic water system may use forced air handling units using blower, heating coil, and ducting to distribute heater air to various zones of the building. These systems are well suited for buildings where such a system already exists for cooling. The forced air circulation system typically mixes 20% outside air with the space return air. In buildings where air cleanliness is imperative, the forced air systems make use of appropriate air-filtering equipment to prevent ingress of dust indoors. In the regions where both cooling and heating are required, a forced air heating system is a sensible choice for cooling and heating, since the heating and cooling systems can share the ductwork and air handling unit. The air handling unit in such cases shall contain both the chilled water and hot water coil.

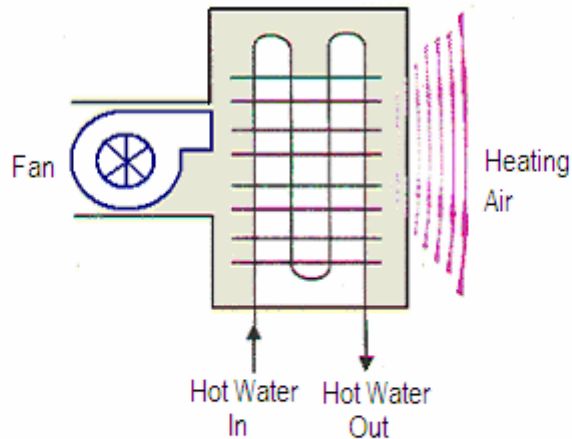

Fig - 2
Hydronic Heating with Central Air Handling Units

Why Hydronic Heating?

1. Hydronic heating systems typically provide more even and steady heating than other systems. Even when the heat exchanger and boiler units are shut off, the system continues to emit heat until the circulating water cools. Some advantages of hydronic systems are the ability to regulate the temperature in each room and to use the same boiler for domestic hot water.
2. Hydronic heating is space efficient and the boiler unit can be located anywhere within the building as long as it is protected against freezing.
3. Hot water can be transported from a heat source to a space over great distances using insulated pipelines.
4. Hot water can be proportionately controlled to operate at various flow rates and temperatures; all from the same heat source.
5. When properly equipped, a hydronic heating system can also be used to heat domestic water for things like cooking, cleaning and bathing. Some heating systems can even be adapted to heat other structures such as greenhouses, garages, swimming pools and snow-melting systems in the driveway.
6. Exterior water heating and snow-melting systems use a heat exchanger placed between the boiler and a secondary fluid such as an anti-freeze solution.
7. A properly designed and installed hydronic system can operate with virtually undetectable sound levels in the occupied areas of a space.
8. *Non-invasive Installation:* It is often very difficult to conceal ducting out of sight within a typical house. The best that can be done in many cases is to encase the

ducting in exposed soffits. Such situations often lead to compromises in duct sizing and/or placement. By comparison, hydronic heating systems are easily integrated into the structure of most small buildings without compromising their structure or the aesthetic character of the space. The underlying reason for this is the high heat capacity of water. A given volume of water can absorb almost 3500 times more heat as the same volume of air for the same temperature change. The volume of water that must be moved through a building to deliver a certain amount of heat is only about 0.03 percent that of air. This greatly reduces the size of the distribution “conduit”. Here’s an example of what that means: A $\frac{3}{4}$ inch diameter tube can carry the same amount of heat as a 14” x 8” duct. Hydronic systems using small flexible tubing are much easier to retrofit into existing buildings than is ducting. The tubing can be routed through closed framing spaces much like electrical cable. Another benefit is that not only a $\frac{3}{4}$ inch diameter tube shall require considerably less material for insulation; the heat loss of the 14” x 8” inch duct is almost ten times greater than that of the $\frac{3}{4}$ inch tube when insulated with the same material. For buildings where utility space is minimal, small wall-hung boilers can often be mounted in a closet. In many cases, these compact boilers supply the building’s domestic hot water as well as its heat. The entire system might occupy less than ten square feet of floor area.

Disadvantages

The installed cost of hydronic systems is higher than that of direct fired forced-air systems, they can be slow to warm up, and there is no capability for central air conditioning, air filtering, or ventilation.

Unless your hydronic heating system also has a fan installed, it cannot provide the cooling, humidification, air filtration or forced air circulation that alternative heating systems can. In addition, excessive heat gains from sources such as sunlight can’t be easily transferred to other areas within the home.

Another factor to consider when installing a hydronic heating system is its vulnerability to damaging impacts and leaks. The system will only function correctly if all piping is in full working order. If the piping becomes damaged, water leaks can rot the flooring and structure of the building.

Design Alternatives

Hot water heating system design can be either a gravity heating system or a forced heating system.

1) **Gravity Circulation:** In a gravity heating system, the circulation of water is a result of the difference in density between the hot water in the supply line and the cold water in the return line. The hot water tends to flow upwards and cold water tends to flow downwards. The elevation of the supply and return lines are therefore important for proper functionality. Gravity systems have many disadvantages:

- The low differential pressure in the system demands increased pipes and valves dimensions. They require very large diameter piping for supply and return mains.
- The gravity system will also have a relative low heating capacity because of low medium temperatures in the heating elements. The low temperature water provided a heat emission rate of only around 150 BTU's per square foot of radiation per hour. Consequently, radiators had to be large.

The gravity system is simple but limited to smaller systems.

2) **Forced Circulation:** In a forced circulation system, a circulating booster pump is used to overcome the objections of the gravity system while retaining all the advantages of heating with hot water. Water is circulated regardless of the temperature forces between hot and cold water. Forced circulation systems allow design using higher water temperatures resulting in higher emission rates. A radiator of 60 square feet with an average water temperature of 170°F will emit heat at a rate of 150 BTU's per square foot per hour, or 9000 BTU's per hour. A radiator of 45 square feet with 197°F water will emit 200 BTU's per square foot per hour; producing the same 9000 BTU's per hour. It is not necessary to be careful with the piping elevations. The pipes, valves and heating elements, radiators and air heaters can be downsized because of higher flow and higher mean temperatures.

HYDRONIC HEATING TERMINAL UNITS

The design of hydronic heating systems is more complex than that of other heating systems and can be more expensive to install. Operating costs can be higher than for simpler systems unless good design, proper operation and maintenance of the system and all of its components are carried out regularly. A variety of heat distribution methods and equipment are available when choosing a hydronic heating system including:

RADIATORS:

Radiators are heat emitters (made up of elements, panels, tubes or blades) which give out heat by natural convection and radiation. Radiators can be classified according to type, i.e. cast iron, radiators, steel radiators and aluminum radiators.

Cast Iron Radiators

They are made of cast elements and assembled with nipples. These have a wide radiant front surface and a thin section at the rear to limit passive heat exchange with the walls.

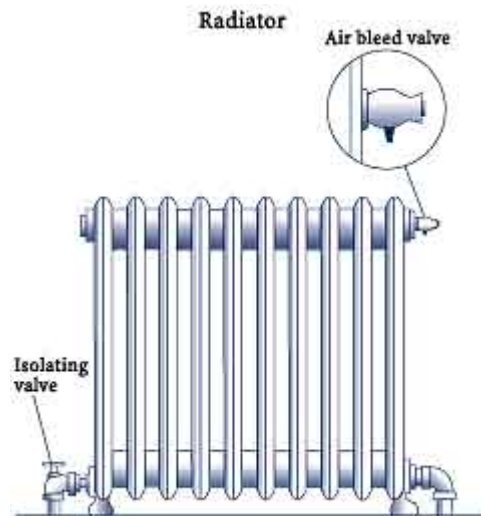

Positive features of cast iron radiators:

- They are resistant to corrosion;
- They do not produce expansion and contraction noises;
- They can be manufactured in a wide variety of lengths as they are assembled from elements.

Negative features:

- More expensive, particularly in relation to panel and column steel radiators;
- High weight which makes installation more difficult;
- Brittleness which can be the cause of fractures during assembly or installation; and
- High thermal inertia which can make ambient temperature regulation less effective.

Steel Radiators

These radiators are constructed by welding stamped plates or tubes. They can be of the panel, column tube or blade type.

Positive features of steel radiators:

- Low cost: they are the most economical panel and column type radiators;

- Low weight: they weigh approximately 65 to 70% less than cast iron radiators with the same heat output;
- They blend in easily with their surroundings: the wide range of range of types and geometrical shapes available can easily be integrated into their environment; and
- Low thermal inertia on the panel types.

Negative features:

- High thermal inertia of the column and tube types (i.e. on high water content types). This characteristic can make ambient temperature regulation less effective;
- The welded panel, blade and column types not assembled from sections; and
- Possible corrosion: these radiators are easily affected by external corrosion unless they have suitable surface coatings.

Aluminum Radiators

These radiators are assembled from components made by extrusion or pressure die casting using nipples.

Positive features:

- Relatively low cost: they cost considerably less than cast iron radiators;
- Lightweight construction: they weight 70 to 75% less than cast iron radiators with the same heat output;
- They are always assembled from sections; and
- They are characterized by limited thermal inertia.

Negative features:

Possible internal corrosion: the presence of alkalis in the water promotes aluminum corrosion. For this reason it is advisable to avoid excessive water softening and the use of chemical inhibitors.

Installing Radiators

It is advisable to install the radiators under a window or along the external walls for the following reasons:

- The cold air currents which form in relation to these surfaces can be overcome more effectively;

- The physiological comfort conditions are improved by limiting the radiation of the human body towards the cold zones;
- The formation of condensation on internal surfaces is prevented or reduced in the area surrounding the heat emitter.

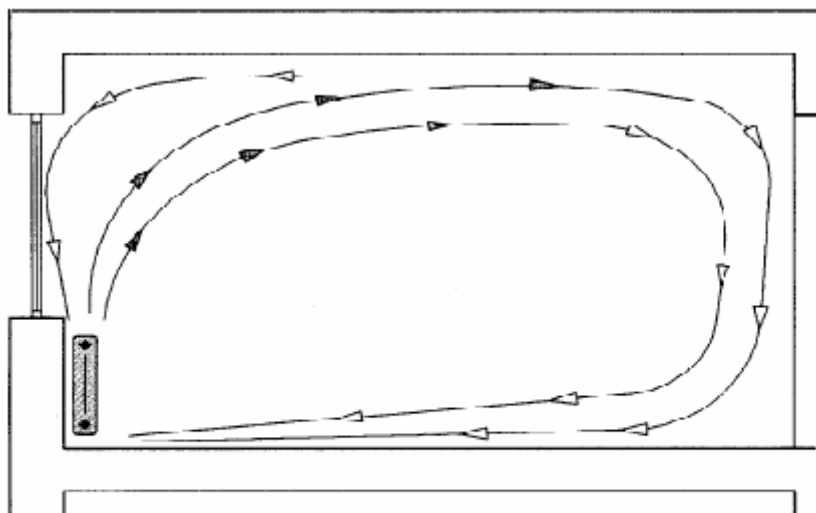

Example of convective movements caused by a radiator

The following distances must be available in order that the radiators can be correctly installed:

- distance from the floor = 10 to 12 cm;
- distance from the walls = 4 to 5 cm;
- It is advisable to stipulate “appropriate distances” of not less than 10 cm for projections above or at the side the radiator (brackets, recesses, shelves etc.).

CONVECTORS:

Convectors are heat emitters which give off heat mainly by convection. They are constructed with finned heat exchangers and operate under natural “draught” conditions. These heat emitters have the following advantages over radiators:

- They are lighter and less expensive for the same output;
- They have a lower thermal inertia; and
- They provide solutions to the specific installation problems.

On the other hand they have the following disadvantages:

- They are difficult to clean so that they should not be used in dusty locations or where satisfactory cleaning is not possible;
- They are not assembled from elements; and
- They cannot be used for automatic air temperature control as their heat output curve has a “bend” (i.e. a significant variation in gradient) for fluid temperatures between 113 and 122°F.

Convectors can be classified on the basis of their structural characteristics, i.e. those with single finned tube, those with finned channels, cabinet convectors and baseboard convectors.

Convectors with Single Fins

They are constructed from tubes with flat fins mounted in a casing to form a chimney draught.

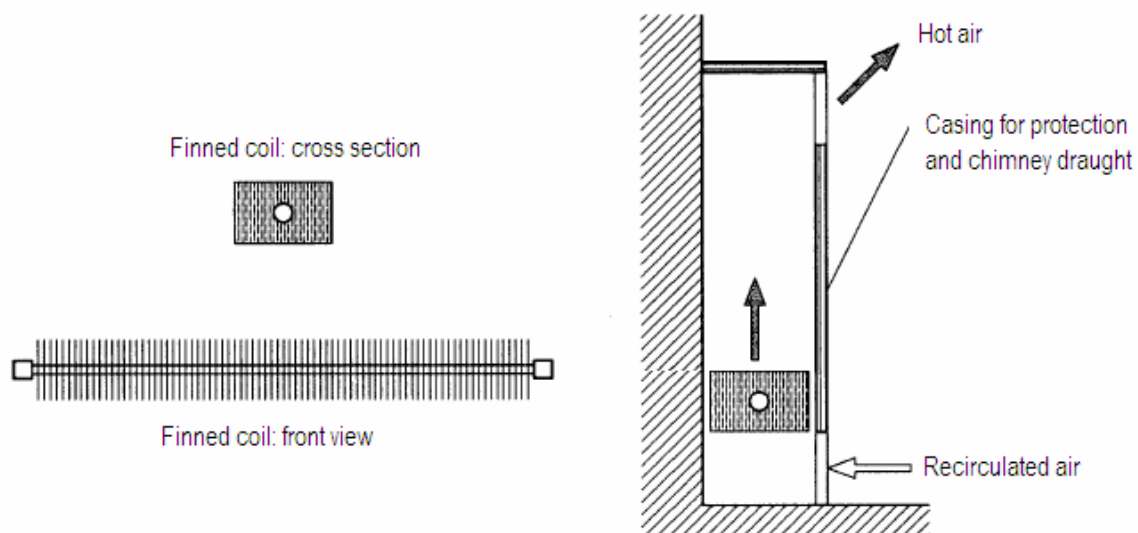

Convector with Single Fins

Cabinet Convectors

These convectors are constructed from a battery of finned tubes mounted within a cabinet which is used to create the “chimney” effect. The heat emission of these convectors can be controlled by adjusting the dampers which vary the quantity of air passing through the battery.

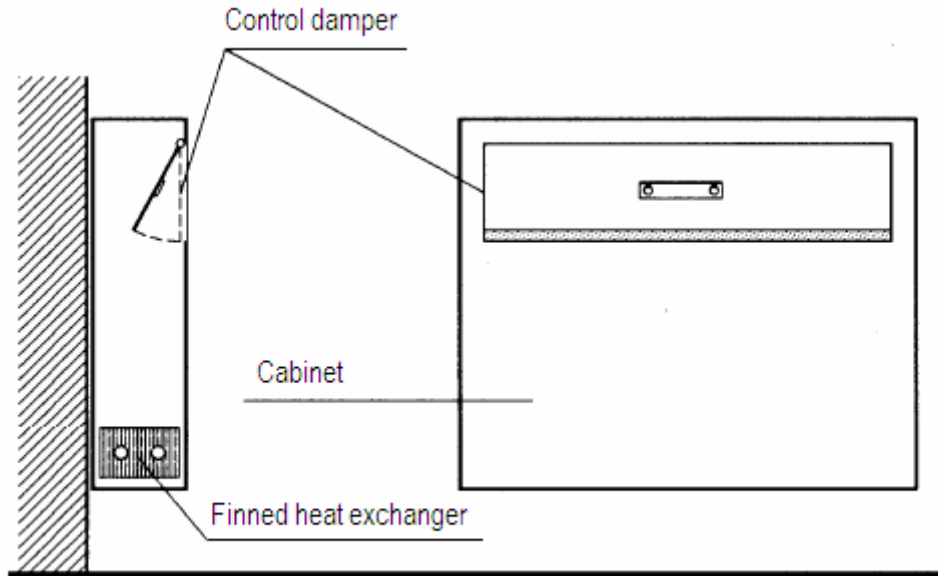

Cabinet Convectors

Baseboard Convectors

Baseboard convectors consist of a length of pipe with attached “fins”. These systems can be purchased with a sheet metal cover or could be concealed in an architectural enclosure or are recessed into floors where they won’t be subject to damage or corrosion.

The dimensions and shapes of these convectors are such that a simple “baseboard” installation, i.e. along the lower strip of the wall, can be achieved.

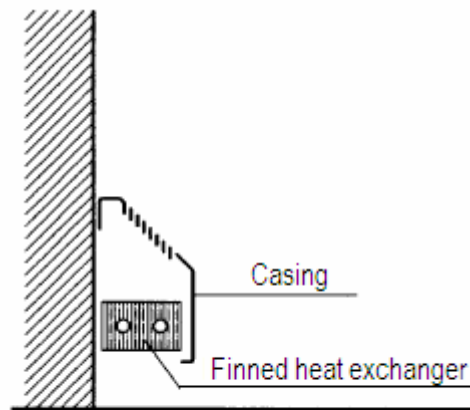

Baseboard Convectors

FAN COILS

Fan coils transfer heat mainly by forced convection. In a typical fan coil system, the air in a room is drawn into the system and is heated over a heat exchanger which is composed of hot-water finned-tube coils. The heating effectiveness of a fan coil depends on the surface area, size of heat exchanger, spacing and thickness of coil fins, the number of

tubes and the performance of the fan. The temperature of the entering water as well as the temperature of the entering air will also influence the heat capacity of the fan-coil.

- The heat output of the fan coil is approximately proportional to the difference between the entering water temperature and the entering air temperature;
- Increasing the rate of water flowing through the coil will increase the heating capacity of the fan coil;
- The increase of the air flow rate flowing through the coil will also increase the heating capacity of the fan coil; and
- A fan coil unit running with lower water temperatures will have the same heat capacity of another similar heat coil with smaller coil surfaces and/or less tubes.

Fan coil units are constructed with:

- one or two finned coils,
- one or two centrifugal or tangential fans,
- an air filter,
- a condensate collection tray,
- a casing.

They are used for heating and cooling homes, offices, meeting rooms, hotels, hospitals, laboratories, etc.

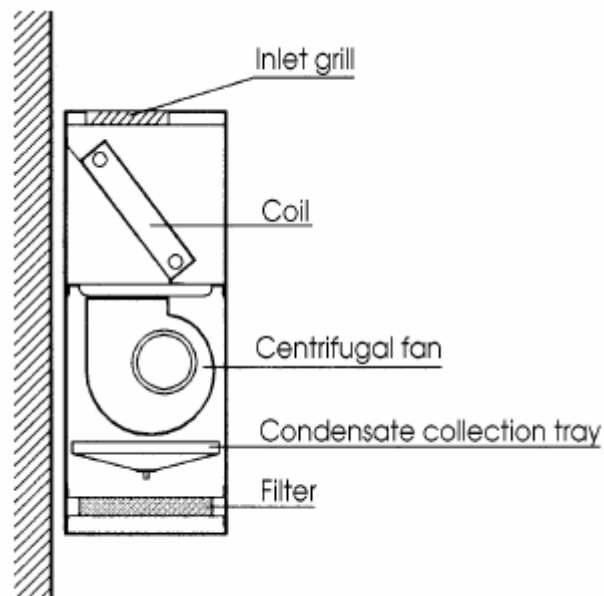

Fan Coil Unit

Classification

Fan coil units may be classified according to the following criteria:

On the basis of position:

- the floor
- the wall
- the false ceiling
- the ceiling;

According to the type of enclosure:

- cabinet
- recessed into structure

On the basis of the position of the fan:

- on the intake (the fan blows air into the coil)
- on suction (the fan sucks air from the coil)

In relation to the characteristics of the air flow:

- with free flow
- within channels

On the basis of the number of coils:

- with a single coil (in 2 tube systems)
- with a double coil (in 4 tube systems, i.e. in systems in which both the hot fluid and the cold fluid circulate at the same time)

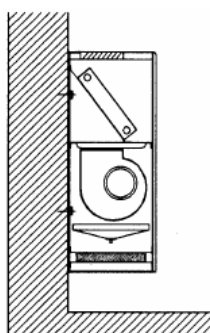

Wall fan coil unit

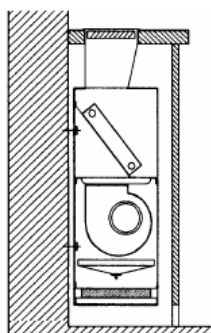

Recessed fan coil unit

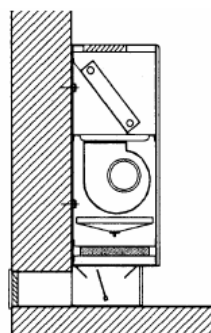

Wall mounted fan coil unit

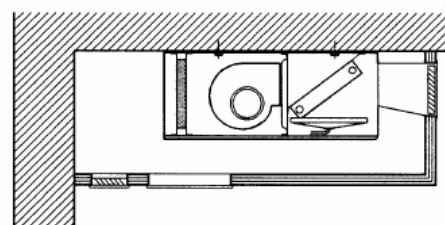

False ceiling fan coil unit

Installing Fan Coil Units

It is advisable to install fan coil units under a window or along external walls for the following reasons:

- It is possible to counteract the currents of cold air which form in relation to these surfaces; and
- The formation of internal surface condensate around the appliance is prevented or reduced.

UNIT HEATERS

Unit heaters are heat emitters which give off heat by means of forced convection. Basically they consist of:

- a hot water finned heat exchanger;
- a fan; and
- a casing

Unit heaters are the most commonly used form of heating due to the following reasons:

1. they provide the air circulation needed;
2. they can be used in conjunction with ventilation systems;
3. they are comparably the least expensive;
4. they provide quick response to temperature changes;
5. they are easy to install;
6. they offer inexpensive expansion for additions;
7. they can be used in conjunction with waste heat applications; and
8. they provide snow load protection which facilitates solar gain

Unit heaters can be divided into two categories based on the direction of their air flow, i.e. horizontal or vertical.

Horizontal Unit Heaters: These are also called “wall” heaters and are used for heating areas which are not very high. They are provided with horizontal or vertical adjustable louvers to control the air flow.

Vertical Unit Heaters: These are also called “suspended” heaters and are used to heat areas with heights of about 20 to 25 meters.

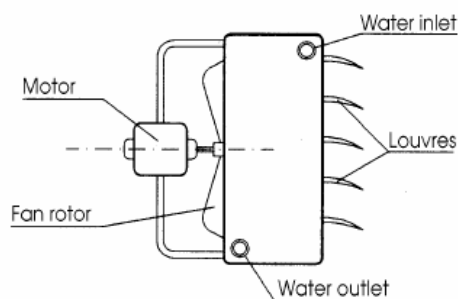

Horizontal Unit Heater

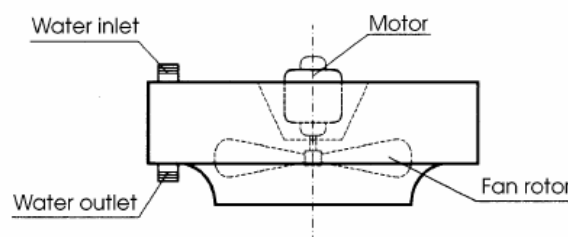

Vertical Unit Heater

Choice of Unit Heater

The following factors must be considered in order to make the correct choice from these types of emitter:

- installation of the unit heaters;
- outlet temperature of the air; and
- noise level.

Installation of the Unit Heaters

The type of unit heater should be chosen so that the positioning of these emitters can be such as to avoid the formation of excessively hot or cold areas.

To achieve this, the following general instructions should be followed:

- install at least two emitters in each area;
- check that the sum of the hourly flow rates of the fans is not less than 3.5 times the volume of the area to be heated;
- arrange horizontal unit heaters with their air outlets facing external walls; the most efficient arrangements are those with the air flow forming a continuous circuit tangential to the walls;
- arrange vertical unit heaters with air outlets which overlap each other;
- direct the flow of hot air against wide glazed zones or against large doors;
- avoid disturbing the flow of air with columns, machines or other obstacles

Some examples of effective installations are given below:

1. Example 1: The horizontal unit heaters are arranged in such a way as to provide a continuous movement of air along the external walls. This arrangement should be used in low, regularly shaped areas.

2. Example 2: The horizontal unit heaters are installed along the main axis of symmetry of the area and their air outlets are directed towards the external walls. This arrangement should be used to heat particularly wide premises.
3. Example 3: The horizontal unit heaters are installed on the external walls and their air outlets are directed towards the adjacent or opposite walls. This arrangement should be used in premises which are not very wide.
4. Example 4: The vertical unit heaters are arranged with their air flows overlapping each other. This arrangement should be used on premises with heights of more than 15 ft.

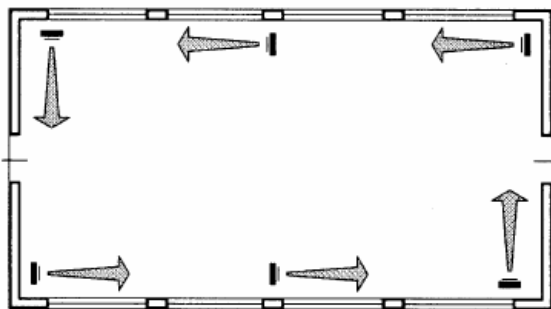

Example 1

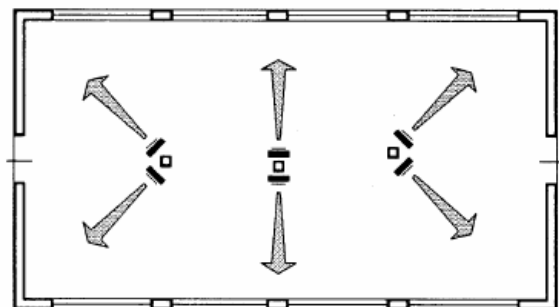

Example 2

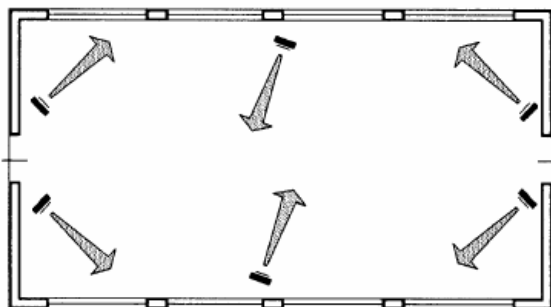

Example 3

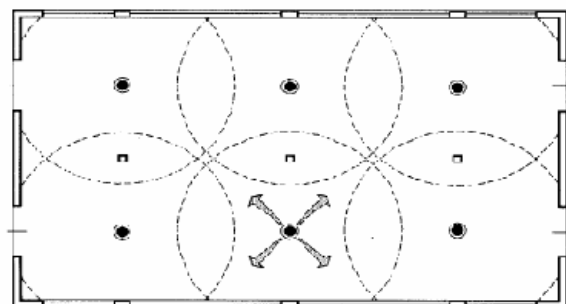

Example 4

HYDRONIC HEATING – PRIMARY ELEMENTS

The basic hot water heating system consists of the following components:

Hot water heater or boiler; circulating pump; expansion tank; distribution piping; radiators in the space to be heated (black iron or steel pipes); finned-tube convectors; unit heaters or under-floor pipes; controls, valves and temperature and pressure gauges (air bleeding valves, pressure relief valves, and pressure regulators).

- 1) **Boilers, or hot water generators**, don't actually boil the water but simply re-heat it (typically 140 - 180°F) prior to releasing it to the heat exchangers. Boilers are generally rated on input and/or output in British thermal units per hour (BTU/h) or in kilowatts. Boiler output should be adequate to offset building design heat loss, piping

losses from exposure to unheated space and any additional heating needs such as swimming pools or hot tubs. These systems are often "closed" with virtually no fresh water makeup. Hot water boilers are often preferred because they normally do not need an operator or special water chemistry, and they run at higher fuel conversion efficiencies than steam generators.

There are two basic boiler control strategies, variable temperature and constant temperature. Variable temperature control is used for systems that heat the living space. Constant temperature control is used when the system also heats domestic water, swimming pools or hot tubs.

There are three different boiler types: gas-fired, oil-fired and electricity powered. Electricity powered boilers are difficult to find and, at this time, are more expensive to operate than either the gas-fired or oil-fired types. Gas and oil-fired boilers are rated through the Energy Star program. Boilers that meet or exceed an 85 percent efficiency rating are labelled as Energy Star compliant. For maximum energy efficiency, look for boilers displaying the Energy Star logo.

- 2) **Commercial Water Boilers:** Commercial water boilers for larger systems come in many shapes, sizes and construction methods and materials. The two basic boiler designs for buildings are fire-tube and water-tube.

In fire tube boilers, hot combustion gases pass through tubes submerged in water. These systems are simple and easy to construct and are generally used in low-pressure applications. The main components that make fire tube boilers energy efficient is the four-pass design, the forced-draft design, the heating surface area and updraft construction.

- **Four-pass design:** The number of passes indicates the amount of time the flue gases pass through the tubes. It has been proven that the efficiency of the boiler is directly proportional to the number of passes. The four-pass design is based on the velocity of the gases being directly proportional to the ratio of the volume of the gases and the flow area. The flue gas has to maintain high flow velocity. The temperature of the exhaust gas is lower; leading to an increase of the overall efficiency of the boiler.
- **Forced-draft design:** The forced-draft design uses a fan to pressurize the combustion air before it is mixed with the fuel, which improves combustion. This design provides air in the required quantities and at the proper pressure, thus reducing excess air.

- **Heating surface area:** Heat transfer is fundamental for efficient and long lasting equipment. Packaged units can offer a heating surface area of 0.047 m²/kW which increases the life of the boiler, reduces maintenance requirements and increases the efficiency of the boiler.
- **Updraft construction:** Updraft construction involves placing the furnace at the lower end of the boiler and running the gases towards the higher end of the boiler. The furnace contains the hottest combustion gases and is designed with a significant clearance from the bottom shell to enable full fluid circulation in the system. Such a construction offers a safer operation and better combustion.

In water tube boilers, the water is contained in tubes located inside a furnace where hot flue gases pass over the tubes, heat the water, and then exit out the stack. Small water tube boilers are usually available in packaged units while larger tubes are assembled in the field. Packaged water tube boilers, using oil or natural gas, have various designs and can have any capacity. They are usually categorized according to their burner type: an atmospheric burner (standing pilot or spark ignition) or a forced convection burner (which has a higher efficiency and better overall combustion).

For boilers to run at peak efficiency, operators must attend to boiler staging, water chemistry, pumping and boiler controls, boiler and pipe insulation, fuel-air mixtures, burn-to-load ratio, and stack temperatures.

- 3) **Circulator, or the circulating pump**, is an electrically driven pump that forces water through the boiler and/or the piping system. Some heating systems have more than one circulator in order to serve separate areas of the building. The circulator pump is selected for the flow rate and the head requirements. A pump must develop enough pressure to overcome the resistance (friction) created in the boiler, piping, fittings, heat distributing units and other parts of the system. When making your selection, do not add the static head pressure (due to the height of the system) to the head pressure rating of the circulator. The following facts may be noted:
 - Centrifugal pumps, in the form of wet rotor circulators or three-piece circulators, are most commonly used in hydronic heating systems.
 - There are four possible pump selections: a large and small pump, either of which can run in high or low speed. Obviously the large pump in high speed offers the maximum performance, but it would be both the most expensive to buy and the most expensive to run. The small pump in low speed is at the other extreme. Again we see the trade-off between initial cost and operating cost ("pay me now or pay me later").

Pumps can also be placed in parallel or in series. It is a good idea to use two pumps connected in parallel in case one should fail, or to have a spare on hand.

- 4) **Isolation Valves at all Zones or Flow Circuits** are often used as an alternative to having separate circulating pumps for each different zone in the building. Individual zone valves are electric and are controlled by their own thermostat so each zone or room in the home can be individually controlled for comfort and energy savings. Manually operated valves are sometimes needed to balance the system in multi-zoned installations, for system shut down, or if a thermostat fails. Valves can usually be one or two sizes smaller than the line they serve. If the pipe is larger than the flow requires (as is often the case for bare pipe systems), know the flow rate and select a valve of the required capacity.
- 5) **Automatic Temperature Control and Zone Control:** These are desirable, using thermostatically controlled flow regulators. Automatic valves regulate the hot water circuit in each room or zone and are actuated by the thermostat for that room. The circulating pump usually runs continually and the valves open or close as required. Alternatively, the pump can be started by a thermostat or aquastat, as one or more zones calls for heat. Three-speed pumps or pumps equipped with variable speed drives are also available, which increase or decrease the flow as needed.
- 6) **Relief Valve:** Every hot water boiler must have a safety relief valve that will keep the pressure at or below the boiler's working pressure. The ASME (American Society of Mechanical Engineers) code states: "Every hot water heating boiler shall have at least one officially rated pressure relief valve set to relieve at or below the maximum allowable working pressure of the boiler. Relief valves shall be connected to the top of boilers with the spindle vertical if possible. No shutoff of any description shall be placed between the relief valve and the boiler, or on the discharge pipe between such valve and the atmosphere."

The discharge of steam through a relief valve is an emergency condition and places a critical demand on the valve. Whenever the temperature of the water in the boiler is about 212°F or above, and the relief valve discharges, the sudden pressure drop causes the water to flash and to steam. The capacity of the relief valve must handle this. There is a vast difference between discharging water and discharging steam. A pound of water occupies 27.7 cubic inches of space. A pound of steam, at atmospheric pressure, occupies 26.8 cubic feet; over 1600 times more space than water. Thus, an ASME relief valve is tested and rated on steam, even though it is a

valve for a hot water boiler. The smallest pressure relief valve available is probably rated at 15,000 BTU/hr, which is also more than adequate.

- 7) **Low Water Cut-Off:** Most boiler manufacturers recommend putting low water cut-offs on hot water boilers. Many local codes will require this. Even though a boiler may be protected from exploding because it has an ASME relief valve, dry firing can still ruin it. Most hot water boiler damage can be traced to low water conditions.

There is a misconception that the pressure reducing fill valve will keep a system full under all circumstances. This is not true. To illustrate the problem, a typical system will have a pressure reducing fill valve set around 12 to 18 lbs and a relief valve set to open at 30 lbs and close at 26 lbs. Should the relief valve open to discharge water due to excess pressure, it is obvious the fill valve won't make up the water lost. Without make-up water replacing the loss through the relief valve, a low water condition can result. There are many other reasons a system can lose water so that a low water condition will result such as leaks in the boiler, piping, or through the pump seals. Carelessness, such as draining a boiler for repair and forgetting to refill the system is yet another common reason for a low water condition. A low water cut-off will save the boiler by not allowing the burner to come on until the low water condition is corrected.

Under certain circumstances, a low water cut-off may not be enough protection. A fuel valve could stick open; contacts could weld closed due to an overload or short circuit making the low-water cut-off ineffective. The best recommendation to cover all installations is to use a combination water feeder and low water cut-off. The feeder portion is usually capable of feeding water into the boiler as fast as it can be discharged through the relief valve. While the feeder cut-off combination will add to the cost of an installation, when compared to the cost of replacing a boiler, it is "cheap" insurance. Remember, codes are minimum requirements that must be complied with. It is always good practice to exceed the code requirements, especially where safety is a concern.

- 8) **Expansion tanks** are used as a reservoir or overflow tank. Water expands about 4% as it heats from room temperature to near boiling. The expansion tank is an essential component of the hydronic heating system used to accommodate an increased volume of water in order to avoid damage and accidents due to high pressure. The expansion tank contains a quantity of air that is compressed as the volume of water rises in the system. In essence, the expansion tank performs two key functions: 1) accept the extra water produced by heating the water in a sealed system and 2)

prevent the circulator from changing the static pressure in the sealed system. The three parameters to take into consideration when designing an expansion tank are its location, its height and its volume. As a general rule, the expansion tank should also be located near the inlet port of the circulator and the volume of the tank should not be larger than the calculated volume value.

Expansion tanks are sized from the volume of water in the loop and the difference between the maximum and minimum operating temperatures. Generally the required volume is less than 10% of the system volume. System water volume and temperature determine tank size. The compression tank acts like a spring on the system, keeping pressure on it at all times.

- If the tank is too small, or becomes waterlogged, the relief valve will open when the boiler is heating and will discharge water. When the heating cycle is over, the water will cool, system pressure will drop, and the feed valve will open and feed water until system pressure is back to “normal”. On the next call for heat, the water will again expand, causing the relief valve to open. The cycle will repeat over and over until the small tank is replaced, another expansion tank is added, or the waterlogged tank drained and properly refilled with the correct air and water charge.
 - If the tank is too large, the system pressure increase may not be enough as the system heats up and approaches boiling, especially at the high point of the system where low static head exists. Proper compression tank sizing is very important for trouble-free system operation, whether it is a pre-charged tank with a bladder separating the water and air, or a standard expansion tank.
- 9) **Air elimination devices** should be installed at each high point in the hydronic system where air can gather. Trapped air must be expelled from the heating system to ensure optimum heating performance and to prevent noisy operation, blockage or even complete damage to the system.

Manual air vents at high points, automatic air vents, float-type air vents, air purgers and micro-bubble absorbers are used to solve the problem. There are two basic types of air vents: automatic and manual. Automatic air vents come in two styles: float type and fiber disc type.

- Float vents have a float attached to a valve, all contained in a shell. When the shell is full of water, the float keeps the valve closed. When enough air accumulates in the shell, the float drops causing the valve to open and the air to pass out, until water again fills the shell causing the valve to close.

- Fiber disk type automatic vents are physically very small; the same size as manual “loose key” or “coin” vents. They use special discs that swell when water touches them. As air accumulates and replaces the water around the discs, the discs dry out, shrink, and open a small vent port.
 - The best air vents are the manual vents which require a small key to open or close them. These are just a small needle valve, metal to metal seat, and are virtually indestructible and cheap. Their only drawback is that they must be manually opened and closed. Air vents for residential heating systems typically have a 1/8" NPT (National Pipe Thread) connection and require no further sizing.
- 10) **Heat transfer devices** such as radiators, convectors, fan-coil units and radiant floors transfer the heat from piped water to the living space.
 - 11) **Heat exchangers** are the elements in the hydronic system that transfer heat to the piped water, or in the case of snow melting systems, the heat is transferred to an anti-freeze solution.
 - 12) **Mixing valves** blend cooler return water with hot boiler water to obtain the desired thermostat temperature.
 - 13) **Controls:** Standard low-voltage or newer programmable electronic thermostats can be used to provide temperature control for the hydronic system. Thermostats are usually connected to - and control the zone valves. When the valve is fully open, an end switch on the zone valve turns the boiler and circulator on. Thermometers and pressure gauges are handy for balancing the system and also to monitor the efficiency of the system. Pressure gauge cocks and thermometer wells shall be installed at appropriate locations to make the routing checks.
 - 14) **Pressure regulator:** The pressure regulator which is actually a pressure reducing valve must be provided on the cold water supply connection. It is used to fill the system initially and will add water when system pressure falls below the valve setting. The standard factory setting is usually 12 lbs. This setting is the correct setting for a static height up to about 18 feet; appropriate for most two-story buildings. For higher static heads, the valve can be adjusted up to 25 lbs. Most systems work best under a moderate pressure of about 15 PSI (100 kPa) for better circulation and to avoid vapor locks (just like automobile systems).
- A 0-100 PSI pressure gage would be specified if the water tank is connected to the domestic water supply, since most city water systems operate in that range. If it is a

stand-alone loop, specify a 0-30 PSI pressure gage, since residential heating equipment is generally required by ASME Pressure Vessel Code to operate in that range.

- 15) **Piping** materials for the hydronic system will vary depending on how the system is used and installed. Copper piping is typically used to distribute the hot water throughout the system; however, if the piping is embedded in concrete it may be made of iron, steel, synthetic rubber or plastic. Take changes in pipe size into account when choosing supports and planning layout. Provide sleeves or adequate clearance where pipes pass through walls or floors. Pipe supports should allow movement. Allow for expansion at the end of and along pipe line, or loop by stopping short of the end wall. For a 100°C change in temperature, steel expands 0.12% in length; various plastics expand 5 to 15 times as much.
- 16) **Draining and Venting:** Both are facilitated if heating lines slope uniformly to one end (or one point). Install drain cocks at the low points and air vents at the high points. One of each may be all that is required for simple systems; others may require several.
- 17) **Pipe insulation** is used to prevent heat loss and to ensure heat is delivered to the living space where it is required. Pipes running through unheated areas, such as crawlspaces, should be insulated with moulded fibreglass pipe insulation.
- 18) **Antifreeze and Corrosion Protection:** This protection is important. Antifreeze should be used if there is any danger of freezing. Use an ethylene glycol solution specially formulated for hot water heating systems. This contains corrosion inhibitors to maintain long-term performance of systems and components. Check the antifreeze solution every year and add inhibitor if needed.

SIZING HYDRONIC SYSTEMS

Hot water heating systems have been traditionally designed for a supply temperature of 180 to 200°F with a 20°F temperature drop (delta T). Equipment manufacturer's selection data are normally indexed to these temperatures as are the practices of many design professionals.

Flow Rate: The required flow rate (in gallons per minute or GPM) is based on the quantity of energy that must be delivered. The volumetric flow rate in a heating system can be expressed by the basic equation:

$$q = h / (cp * \rho * \Delta T)$$

Where,

- q = volumetric flow rate, (gal/min)
- h = heat flow rate, (BTU/h)
- c_p = specific heat capacity, (BTU/lb F)
- ρ = density, (lb/ft³)
- ΔT = temperature difference (°F)

The basic equation can be modified for the actual units (SI or imperial) and the liquids in use.

For water with a temperature of 60°F, the flow rate can be expressed as:

$$q = h (7.48 \text{ gal/ft}^3) / ((1 \text{ BTU/lb F}) (62.34 \text{ lb/ft}^3) (60 \text{ min/h}) \Delta T) \quad \text{or}$$

$$q = h / (500 * \Delta T)$$

Fluid Velocity: The acceptable range for water velocity in most applications is between three and seven feet per second (3-7 fps). Velocities lower than 3 fps represent large diameter pipes that are uneconomical to install, and velocities higher than 7 fps represent too small pipes that will cause large pressure drops and uneconomical sizing of circulator pumps. Going outside of this acceptable design range can also cause problems with air entrapment in the water (if too slow) and pipe erosion and noise (if too fast).

Pipe Size: The pipe size is determined from the standard selection charts based on the equation $q = A * V$, where A = area of the pipe, $\pi * d^2/4$, and V is the velocity of flow in fps. When the two parameters (GPM and velocity range) are fixed, the optimum pipe diameter can be selected. For example, if a system requires 90 GPM, we can select either 2-½" diameter pipe at 6 fps or 3" diameter pipe at 4 fps, both within the acceptable velocity range. Most flow rates will offer a choice between a couple of pipe diameters within the acceptable velocity range.

Distributing the hot water

There are four basic piping systems used in hydronic heating systems to distribute heated water:

- 1) **One-pipe series loop systems** are the simplest version and use a single pipe that runs through a series of rooms. Heating devices are connected to the pipe wherever they are needed but no individual room control is possible within the loop. It is

possible to divide this single loop into a series of zones using zone valves to control temperature within specific areas of the home. Each loop in a zone valve controlled loop should have shut-off and drain valves in the boiler room for isolation in the event of a system leak.

- 2) **One-pipe systems** with diverting tees are similar to the series loop systems in that a single pipe is used but the heating units are installed in side circuits off the main pipe. In this system, a special pipe fitting is installed to force the heated water out of the main pipe to a heating device prior to returning the water back to the main pipe. In this system a thermostat control can be installed in each room; however, individual rooms may not reach the desired temperature setting due to water cooling along the way.
- 3) **Two-pipe direct return** has the fluid returned directly to the boiler by the shortest path. The hot water delivered to the first radiator is also the first to return to the boiler. This progresses through the circuit so that the last radiator is the last to return its cooler water to the boiler. With the direct return, units closest to the boiler tend to get too much flow and those on the end of the line get too little. There is a tendency for the radiators closest to the boiler to short-circuit the water so the units farther away do not get proper circulation. This system should be installed using balancing valves and carefully balanced.
- 4) **Two-pipe reverse return:** In a reverse return loop, the water in the return runs parallel with the supply pipe until the last coil has been supplied. In this system, the first radiator to be fed hot water has the longest return, and the last radiator to be fed has the shortest return. It is more expensive to install because more piping is required than the two-pipe direct return system, but it functions much better because it results in more uniform or balanced flow as long as the supply and return drops have the same size and length.

The concept of direct return vs. reverse return is further described below.

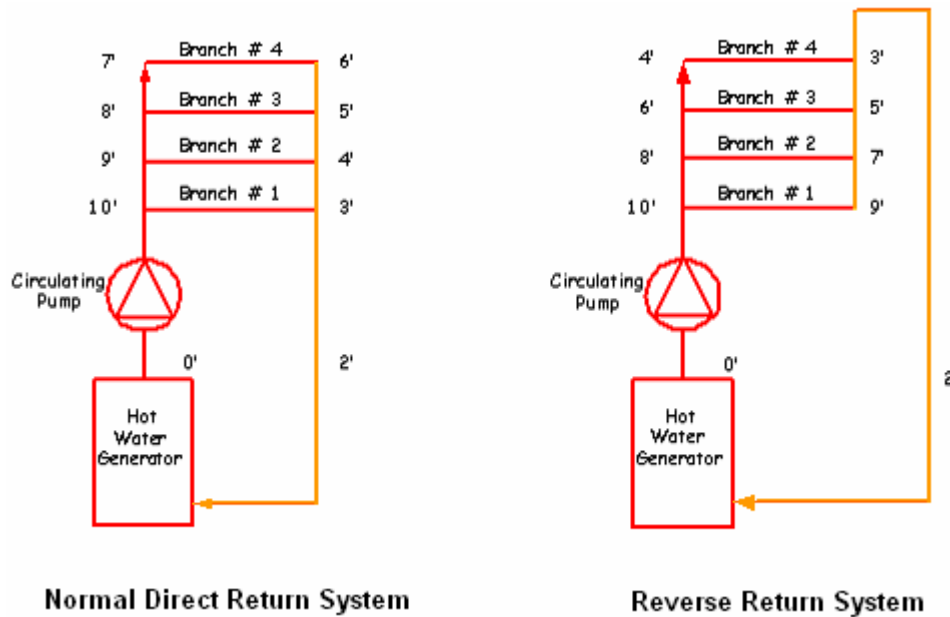

Normal Direct Return System

Reverse Return System

Case #1 – Direct Return System: Consider a system comprising of hot water generator, circulator and hot water distribution system serving four branches. As the water moves away from the circulator, the pressure differential across each circuit becomes less and less. On branch 1, the system has 10' of head pressure on the supply and 3' on the return side of the zone. That means there is a pressure differential of 7' which will cause a certain amount of flow to take place in that zone. At the farthest zone which has 7' of head pressure on the supply and 6' on the return side, only 1' of pressure differential exists across this zone. A difference in pressure is what causes water flow and the greater the pressure differential, the greater shall be the flow rate. In the scheme above, the farthest circuit might have no-flow or very scarce flow.

How do we solve this imbalance problem?

Case #2 – Reverse Return System: The reverse-return piping provides an answer to this problem. Reverse-return maintains equal pressure drop throughout the entire piping system and ensures adequate flow to all the branch circuits. There is a bit more piping involved, but maintaining water at every point makes it well worth installing.

Notice the length of the circuit via branch 4 from the pump discharge back to the hot water generator and via branch 1 is same resulting in somewhat equivalent pressure drop in both circuits. Consider putting balancing valves on the return side of each circuit. By appropriate setting, the pressure drop in each circuit shall be the same. With equal pressure drops in each circuit, there is no “path of least resistance”, and so there will be adequate flow in each circuit.

Note that the two-pipe systems are more expensive than either of the one-pipe systems but water in each of the pipes travels shorter distances, returns to the boiler more quickly and allows greater heat control in individual rooms or zones.

Control Strategies

When a boiler is used for space heating, the simplest control strategy is to have the thermostat control the burner and circulator together. This easily adjusts the heat to your needs and provides the lowest operating costs. Programmable thermostats can be purchased and set up with the boiler and circulator to allow you to control the time and temperature settings of your heating system. A programmable thermostat is one of the most energy efficient items you can add to your heating system.

A second control strategy is to always keep the boiler hot and have the thermostat turn the circulator on and off. Operating costs for this strategy will be higher due to continual heat losses.

A third method of space heating is to adjust the boiler temperature to compensate for the temperature outside on the north side of the house. In this system, an externally mounted thermostat records outdoor temperatures and an internal thermostat adjusts interior zone valves to comfortable heating levels. This method is more energy efficient than the other temperature control strategies.

If your boiler is also used to heat domestic water it must be maintained at full temperature, even when living space heating isn't needed. This leads to increased operating costs from high stand-by heat losses. Separate water heating is recommended for energy efficiency.

Installation hints

1. Install a programmable thermostat with the heating system. Set it to turn heat down when your home is empty and to turn the heat up before you return home.
2. Install extra heating capacity in the bathroom, most people prefer a warmer bathroom.
3. Install a floor heater or recessed tube piping in front of glass patio doors to offset the chill caused by the large glass area. Allow at least 20 cm between the heater and the window.
4. Install a return air grille in the floor at the opposite side of the room from the heating device to improve cold air removal.

5. Clean heating devices regularly to remove dust and keep air circulating properly.
6. Install hot water to anti-freeze heat exchangers and piping systems under steps, sidewalks and driveways to melt snow and ice, improving safety outside your home during winter.
7. As a minimum, bedrooms should be zoned separately from living and dining areas.
8. Rooms with southern exposure should be zoned separately from those with other exposures.
9. Radiant floors have lower water temperature requirements than convection units and these must be on separate zones.

System Startup

Most air problems can be eliminated by careful design, good maintenance, and proper initial startup of the system. The most often overlooked part of a forced hot water system is proper startup. Once a system has been installed, flushed, and filled to the proper static head, the boiler should be fired and slowly heated to at least 225°F water temperature and held there for about one-half hour. This will liberate the entrained air in the water and send it to the expansion tank. The hotter the water, the more air it will liberate. The circulating pump(s) should be off during this initial heating. Now, allow the boiler to cool to normal operating temperature and start all circulators and open all the zone valves, if used. Again, run the water temperature back up to at least 225°F and circulate all the water for 15 to 30 minutes. This will drive most of the air out of the fresh water, and as long as there are no leaks in the system, air problems will be prevented. Anytime the system is drained, say for some repairs, and then re-filled, the startup procedure should be repeated.

HOT WATER RADIANT FLOOR HEATING

Radiant floor heating is accomplished by circulating hot water through lines of plastic pipe, either placed in sand below the floor, or right in the concrete itself. Most typically, a thermoplastic or synthetic rubber tube is used on 6-12" centers, cast in the center or placed under the slab. Warm water is pumped through these tubes from manifolds placed at an accessible location, usually at one end of the space.

Radiant floors transfer heat through direct conduction, direct radiation and gentle convection. The combination of the three modes of heat transfer makes this one of the most comfortable systems. A hydronically heated slab floor provides very even temperatures and is the most popular and cost-effective system for heating-dominated

climates. An advantage to using this type of system is that it is very energy efficient. Radiant heat floors evenly heat rooms using lower water temperatures than other hydronic systems, thus reducing energy consumption. They offer benefits such as thermal comfort, energy efficiency, quietness, cleanliness, versatility, durability and minimized stratification effect. The main disadvantage is their slow response time compared to other hydronic systems.

Radiant floor systems can be installed in one of three ways:

- Slab-on-grade system
- Thin-slab system (lightweight concrete, gypsum under layment)
- Dry System (above deck system, below deck system)

Radiant Heating Design Principles

Systems are designed using the same principles outlined for hot water space heating. Unlike systems that heat air, a heated concrete floor slab should be controlled by monitoring the slab temperature directly. A heated concrete floor slab can usually provide 30-50% of the total conductive heat loss of a space. Most often, another type of a hot water system (bare pipes, finned pipes, unit heaters or other system) is installed to supplement the floor system on cold nights.

Most of the equipment is the same: heater or boiler, circulating pump, expansion tank, valves and controls. The following comments are specific to floor heating:

Water temperature

For floor heat, hot water temperature can be much lower than for space heating; 100 - 140°F rather than 190°F. The floor temperature of a large area is best controlled by regulating the water temperature, rather than by starting or stopping the flow. Control of small sections may be more precise and adjustable if line thermostats regulate flow to each section. Water temperature will be 50-60°F warmer than the floor when pipes are placed in the concrete and about 75°F warmer when they are in the sand below.

It is often useful to know the floor temperature. One way to do this is to make thermometer wells in the concrete. An ordinary thermometer (or electronic temperature probe) in contact with the floor can measure temperature directly. It works best if covered with small slab of foam insulation so it is kept at floor temperature. Cut a small groove in the insulation if it is over the thermometer.

Piping

Usually, this is plastic. Polybutylene pipe made for hot water service is recommended. Higher strength 125 PSI (850 kPa) polyethylene can also be used, as well as soft copper tubing. Connections should be made outside the floor using double stainless steel clamps. Floor heat may require long runs of smaller pipe, thus pipe size must be adequate for the flow. For complete situations, get expert advice for checking flow and pressure loss, otherwise, the following is a safe guide for a minimum pipe size, although larger pipes can be used:

Pipe Loop Lengths	Pipe Diameter
Up to 100 ft	0.5"
Up to 200 ft	0.75"
Up to 325 ft	1.0"
Up to 500 ft	1.25"

Water flow should be higher than for space heat to keep the temperature more uniform. Use a temperature drop of 10-15°F for calculating flow rates.

Radiant floor heating has a number of advantages:

1. Warm floor dries quickly
2. Snow and ice melt faster
3. Heating is very uniform
4. Floor has high thermal mass, thus retains heat for a long time

It also has some disadvantages:

1. Relatively high cost compared to other methods
2. System can be damaged if the floor cracks
3. Slow to react to sudden changes in demand (large door opened, large cold machine brought in)
4. Not suitable for occasional use
5. By itself, may not maintain temperature during the coldest weather

6. The most serious drawback to floor heat is slow reaction time. You may find it necessary to have a supplementary space heater (separate unit heater or furnace) for quick response when cold-weather servicing is critical.

System Design

The best floor temperature is 77 - 86°F; warmer floors are uncomfortable and cooler ones are less effective. The amount of heat transferred from the concrete floor depends on both floor and air temperatures. Heat input to the floor will depend on the inlet water temperature, pipe spacing and water flow, provided that the heating unit has enough capacity to keep up to the floor heat loss.

Heat output from floor to air is given by the following equation:

$$h = 2.11 * (T_f - T_a)$$

where,

- h = heat output from the floor, BTU/sq-ft
- T_f = floor slab temperature, °F
- T_a = room air temperature, °F

For a floor at 86°F and air temperature of 58°F, heat output would be $2.11 \times 28^\circ\text{F} = 59$ BTU/sq-ft. As the building cools below 58°F, the heat output will increase. Design for 60 BTU/sq-ft and size the heating unit slightly larger to account for system losses.

It is possible to get by with a smaller heating unit, down to about 50 BTU/sq-ft, if cooler floors are acceptable. This heat output will keep a reasonably well-insulated shop at 50 - 58°F but does not have extra capacity for reserve heat. It is not feasible, however, to obtain greater capacity from the floor system, since this would require a floor temperature too high for comfort. The system will have to be larger if auxiliary unit heaters are supplied from the same boiler system.

Water flow and pump capacity are calculated as outlined earlier; using equation:

$$q = h / (500 * \Delta T)$$

where,

- q = water flow rate (gal/min)
- h = heat flow rate (BTU/h)
- ΔT = temperature difference (°F)

The ΔT is usually taken as 9-16°F to maintain uniform conditions. Floor heating pipe is usually placed in loops running from a supply and back to a return header. Flow through each loop, for the purpose of checking pressure drop and sizing valves, is thus the total flow divided by the number of loops. Pipe may also be laid out in a continuous spiral around the building but this will require larger pipe owing to the longer loop length. The header system is normally of steel pipe, with T-fittings or nipples welded on for attaching the floor lines. The header should be sized for the total water flow in the system. Valves are recommended on each floor line to balance or control flow; one on the supply and another on the return are best in case one loop springs a leak.

Example:

Design a floor heating system for a 32' x 50' room. Floor area inside the foundation is about 30' x 48' = 1440 sq-ft. Calculate system size based on 70 BTU/sq-ft heat input.

Solution

Room floor area = 1440 sq-ft

- 1) Calculate system size based on 70 BTU/sq-ft heat input.

Total Heat input = 70 BTU/sq-ft x 1440 sq-ft = 100800 BTU (or ~ 30 kW capacity)

- 2) Determine flow rate for an inlet-outlet hot water temperature change of 10°F across the system

$$q = h / (500 * \Delta T)$$

$$q = 96600 / (500 * 10)$$

$$q = \sim 20 \text{ GPM}$$

- 3) Determine number of loops and water quantity per loop

Each loop is about 100 ft (~2 x 48') long, thus ¾" pipe will be adequate (Note: double loops of 184 ft length could be run to reduce valves and connections).

Room width = 30 ft

Pipe spacing = 1.5 ft

Number of lines = 30 / 1.5 = 20

Therefore, use 20 lines or 10 loops

Water flow in each loop = 20 / 10 GPM = 2 GPM

- 4) Size the header system:

For a flow of 20 GPM, 2" (50 mm) pipe is more than adequate.

5) Estimate the volume of the system

1000 ft of $\frac{3}{4}$ " floor pipe x 0.025 gallons per ft = 25 gallons (i.e. at a 100 ft loop x 10 loops; the $\frac{3}{4}$ " pipe has a holding capacity of 0.025 gallons per ft of pipe).

60 ft of 2" mm header x 0.16 gallons per ft = 9.6 gallons (i.e. at 2 x 30 ft of supply & return header; the 2" pipe has a holding capacity of 0.16 gallons per ft of pipe).

Boiler unit volume (estimated) = 5 gallons

Total = 39.6 gallon

Minimum expansion capacity required is 5% of 39.6 gallon = 1.98 gallon; obtain an expansion tank with at least 2 gallon net expansion capacity.

Heated Concrete Slab Floors Installation

Floor heating pipe may be laid either in sand layer below the concrete or directly in the concrete. The former is easier to do and safer from leaks caused by floor cracks. The latter is slightly more efficient. When concrete cures it shrinks, causing natural cracks to occur. Where pipe is placed in the floor, reinforcing is required to reduce cracking to small hairline cracks. This reinforcing can benefit any floor, but less is needed if control joints are part of the floor design (which cannot be done with in-floor pipes). To control cracking, the recommended cross-section area of reinforcing steel is 0.16% of the cross-section area of the floor slab. When selecting a heated concrete slab floor, it is important to consider many factors:

1. The tubing you use must last as long as the concrete itself, so make sure it has been developed for your specific purpose.
2. The type of concrete, and the way it is mixed will have a long term effect on the durability and usefulness of your floor.
3. For floor reinforcement, there are three basic methods used: re-bar, re-mesh and "fiber-mesh". The latter is an additive to the wet concrete and reportedly can offer the most integrity and longevity. Spend some time researching the best means of reinforcement for your project. Remember that you will need to secure your heating tubing to something and a reinforcement mesh might be the best choice.
4. Insulation: It cannot be stressed enough that a heated concrete slab floor should be insulated around the perimeter and as deep as the frost line in your area. Some reports indicate that up to 50% of your heat can be lost out the perimeter of

a heated slab if no below grade insulation is installed. The best type of insulation to use is one of the extruded styrene boards, usually 1.5 - 2" inches thick.

5. Engineering: A good design and plumbing plan are the keys to a well designed heated concrete slab floor. A well designed system will include an appropriate boiler and pump sized to handle the load. Also important is a means of balancing the flow of hot water to achieve even floor temperatures.

The factors to take into consideration during the design of a radiant floor system are:

- a. dimensions of the space
- b. space heating loads
- c. ease of tube installation
- d. location of manifold stations
- e. position of control joints
- f. zoning of the spaces
- g. type of floor covering
- h. length of pipe circuits
- i. horizontal spacing between the tubes
- j. position of exterior walls
- k. possibility of driving fasteners in the floor

The following guidelines should be considered as well:

- a. route the hottest fluid first along the exterior walls of a room
 - b. maximize straight runs and minimize bends and corners
 - c. limit the length of the circuits with respect to the tubes
 - d. design the circuit for room-by-room zoning
 - e. limit the passage of pipes through control joints
 - f. place the tubes according to the grid (slab-on-grade)
 - g. avoid tube crossover
 - h. avoid tube perforation
-

SECTION #6**ELECTRIC HEATING**

Electric furnace using resistance heating converts nearly 100% of the energy in the electricity to heat. From energy management and environment conservation point of view, electric heating is not a recommended choice for heating. Since most electricity is produced from oil, gas or coal generators that convert only about 30% of the fuel's energy into electricity and after accounting losses due to transmission and distribution, converting electricity back to heating doesn't make sense.

Electrical Resistance Space Heating Equipment

Electric resistance heat can be supplied by centralized forced-air furnaces, zone unit heaters and heat pumps.

Central Electric Furnace

In a central electric furnace, air is blown over electric heating coils and then distributed through the ductwork. This type of furnace is much simpler than a fuel-fired one, because no combustion air or exhaust is needed. Therefore, these units have an efficiency rating of 100%, meaning that all of the heat created goes into heating. However, this figure can be misleading. A lot of energy is lost producing and transporting electricity to the house, and it shows up on the energy bill. As with all forced-air systems, leaky ducts in a poor distribution system can lead to hefty additional heat losses. Electricity rates vary, but in most places a central electric furnace is the most expensive type of heating system to run.

Zone heaters distribute electric resistance heat more efficiently than electric furnaces because you set room temperatures according to occupancy. In addition, zone heaters have no ducts that can lose heat before it reaches the room. However, electric furnaces can accommodate central cooling easier than zone electric heating, because the air conditioner can share the furnace's ducts.

Typical zone electrical space heating equipment include baseboard units, wall units, unit heaters, portables, ceiling units, and insulated conductors embedded in the ceiling or floor. Here are several options for electric resistance space heaters.

- 1) **Baseboard Heaters:** Sometimes called electric strip heaters, baseboard radiation is a fairly common heat source and heating system. Compact heating elements enclosed in protective and decorative linear housings are permanently installed along the lower part of one or more room walls; typically near the intersection with the floor. Room air heated by the resistance element rises and is replaced by cooler room air, thereby establishing a continuous convective flow of warm air while in operation.

Although various control schemes are possible, baseboards are individually controlled. Electric baseboards are cheap to install but expensive to run, although if used to heat only occupied rooms, they can be less costly than a central electric furnace.

- 2) **Wall Units:** These heaters may be flush-mounted or recessed, and use a radiant or ceramic panel, heating coils, or other form of heating element. They come with or without a built-in fan and thermostat. These units are often used for spot heating in areas such as building entrances and where higher temperatures are needed.
- 3) **Ceiling Units:** These are similar to the wall units in type, but designed for ceiling installation. Units may include lighting devices (e.g., restrooms).
- 4) **Deep Heat Systems:** These systems are used in northern climates where it may be effective to bury electric heaters in a sand bed beneath the concrete floor of the warehouse, commercial space, or garage. These large thermal masses can often be heated during the off-peak period to provide economical space heat during occupied hours. Since most people are more comfortable when their feet are warm, these systems have also been reported to provide very pleasant work environments even in the most extreme of weather conditions.
- 5) **Duct Insert Heaters:** Heating elements are inserted in the ducts of forced air heating systems, either at the fan location or near supply air outlets. Heaters may be step-controlled in accordance with the amount of heat needed. Automatic safety cut-offs interrupt current on either over-temperature of unit or fan failure.
- 6) **Heating Cables:** These are insulated resistance heating elements manufactured in various lengths and wattage's and are suitable for installation in the ceiling plaster or in/under concrete slabs. This method of heating evenly distributes the heat source and produces a low temperature radiant heat surface. This method has been used in large open buildings such as warehouses, garages, hangars, etc.
- 7) **Unit Heaters:** These heating elements are used with a fan or blower to force air into the conditioned space. Certain types are classified as heater-ventilators and perform the function of both controlled heating and ventilating. These units have been used primarily in schoolroom heating, but can be used for many commercial or industrial applications where ventilation is required.
- 8) **Electrical Tubular Heaters:** These are steel or aluminum tubes usually round or oval in section. They consist of an electrical heating element which extends from end to end and is surrounded by air. The surface temperature is about 80°C. A single

tube at 50mm diameter has an output of about 180 Watts per meter length and tubes may be mounted in banks, one above the other, for higher outputs. An electrical skirting heater with an output of 400 Watts per meter run is typical of some installations requiring background or low level heating. Tubular heaters are used in churches, under pews, in greenhouses, conservatories and foyers. They can be placed at the bottom of high windows to prevent draughts of cold air or be set to prevent frost in greenhouses or conservatories.

9) **Radiant Heating:** Instead of circulating heat by moving the air in the room, a radiant system heats objects and people. There are several types of electrical radiant heaters:

- **Infrared Radiant Heaters:** These heaters generate infrared radiation, heating all objects in their "line of sight," or radiation path. The electrical elements used are similar to those fitted to luminous fires but, for a given rating, are commonly longer as shown below, and arranged to operate at about 900°C. Equipment is available with either metal sheath enclosed element, quartz tubes and reflector lamps. They are all used with a directional reflector. Wall or ceiling models of these are suitable for kitchens and bathrooms with ratings up to 3 kW. Infrared heating is used in areas where heating the entire space through convection would be difficult or expensive in comparison to keeping people comfortable such as warehouses, garages, etc.
- **Quartz Lamp Heaters:** The elements of this type of heater operate at about 2000°C and consist of a tungsten wire coil sealed within a quartz tube containing gas and a suitable halide rating of elements about 1.5 kW. These are used in large spaces either where the requirement is intermittent or where only local areas require spot heating.
- **High Temperature Panels:** These consist of either a vitreous enamelled metal plate or a ceramic tile behind which a resistance element is mounted within a casing. Panels of this type operate at a temperature of about 250°C, have ratings in the range 750 W to 2 kW, and are normally used in washrooms in industrial settings. These low-density radiant heaters can be mounted on walls or ceilings to provide spot heating.

Heat Pumps

Heat pumps are designed to move heat from one fluid to another. The fluid inside the home is air and the fluid outside is either air (air-source) or water (geothermal). In the

summer, heat from the inside air is moved to the outside fluid. In the winter, heat is taken from the outside fluid and moved to the inside air.

A heat pump is an electrical device that functions by moving (or pumping) heat from one place to another. Like a standard air-conditioner, a heat pump takes heat from inside a building and dumps it outside. The difference is that a heat pump can be reversed to take heat from a heat source outside and pump it inside. Thus a heat pump can be used for both summer cooling and winter heating cycles. Note the following facts:

1. In the heating mode, heat pumps are far more "efficient" at converting electricity into usable heat because the electricity is used to move heat, not to generate it.
2. Because they move heat rather than generating heat, heat pumps can provide up to 4 times the amount of the energy they consume.
3. If you heat with electricity, a heat pump can trim the amount of electricity you use for heating by as much as 30 to 40%.
4. High-efficiency heat pumps also dehumidify better than standard central air conditioners, resulting in less energy usage and more cooling comfort in the summer months.

The heat pumps are divided into two major groups: air source (air-to-air) systems which draw heat from the air, and ground source (earth energy) systems which draw heat from the ground or underground water.

Air Source Heat Pump

The most common type of heat pumps is the "air-source heat pump" which uses outside air as the heat source during the heating season and the heat sink during the air-conditioning season.

Most heat pumps operate at least twice as efficiently as conventional electric resistance heating systems. They have typical lifetimes of 15 years compared to 20 years for most furnaces.

Heat pumps use the vapor compression cycle to move heat. A reversing valve allows the heat pump to work automatically in either heating or cooling mode. The heating process is as follows:

1. The compressor (in the outside unit) pressurizes the refrigerant which is piped inside.

2. The hot gas enters the inside condensing coil. Room air passes over the coil and is heated. The refrigerant cools and condenses.
3. The refrigerant, now a pressurized liquid, flows outside to a throttling valve where it expands to become a cool, low pressure liquid.
4. The outdoor evaporator coil, which serves as the condenser in the cooling process, uses outside air to boil the cold, liquid refrigerant into a gas. This step completes the cycle.
5. If the outdoor air is so cold that the heat pump cannot adequately heat the home, electric resistance strip heaters usually provide supplemental heating.

Periodically in the winter, the heat pump must switch to a "defrost cycle" which melts any ice that has formed on the outdoor coil. Packaged systems and room units use the above components in a single box.

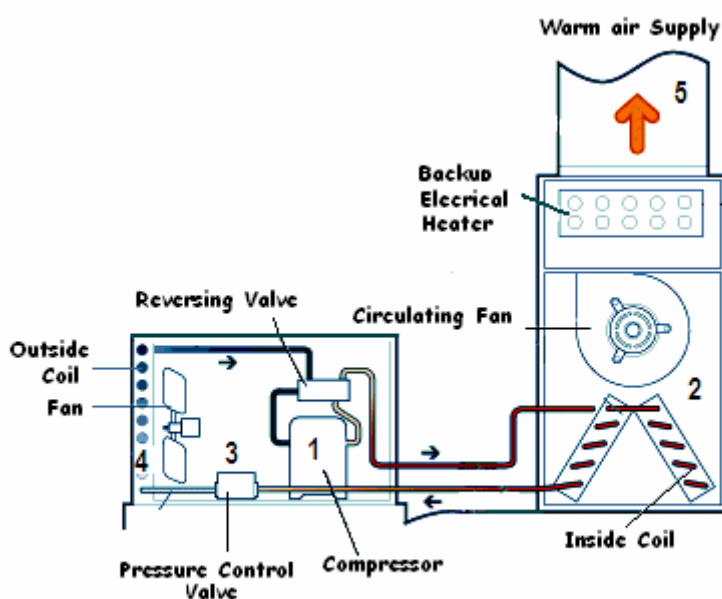

HEAT PUMP UNIT

At outside temperatures of 25°F to 35°F, a properly sized heat pump can no longer meet the entire heating load of the space. The temperature at which a properly sized heat pump can no longer meet the heating load is called the balance point. To provide supplemental backup heat, many builders use electric resistance coils called strip heaters. The strip heaters, located in the air-handling unit, are much more expensive to operate than the heat pump itself. The strip heaters should not be oversized as they can drive up the peak load requirements of the local electric utility.

A staged, heat pump thermostat can be used in concert with multistage strip heaters to minimize strip heat operation. To overcome this problem, some houses use a dual-fuel system that heats the home with natural gas or propane when temperatures drop below the balance point.

Air-source heat pumps should have outdoor thermostats which prevent operation of the strip heaters at temperatures above 35°F or 40°F. Many mechanical and energy codes require controls to prevent strip heater operation during weather when the heat pump alone can provide adequate heating.

The proper airflow across the coil is essential for the efficient operation of a heat pump. During installation, the airflow rate must be checked to ensure that it meets the manufacturer's recommendations.

Air Source Heat Pump Efficiency

The heating efficiency of a heat pump is measured by its Heating Season Performance Factor (HSPF), which is the ratio of heat provided in BTU per hour to watts of energy used. This factor considers the losses when the equipment starts up and stops, as well as the energy lost during the defrost cycle.

New heat pumps manufactured after 2005 are required to have an HSPF of at least 7.7. Typical values for the HSPF are 7.7 for minimum efficiency, 8.0 for medium efficiency, and 8.2 for high efficiency.

Variable speed heat pumps have HSPF ratings as high as 9.0, and geothermal heat pumps have HSPFs over 10.0. The HSPF averages the performance of heating equipment for a typical winter in the United States, so the actual efficiency will vary in different climates.

To modify the HSPF for a specific climate, a modeling study was conducted and an equation was developed that modifies the HSPF, based on the local design winter temperature. In colder climates, the HSPF declines and in warmer climates, it increases. In Climate Zone 4, the predicted HSPF is approximately 15% less than the reported HSPF.

Ground Source Heat Pump

Also known as a geothermal system, this type of heat pump uses underground loops to absorb heat from the earth or, in other words, it transfers heat between your facility and

the ground. Ground-source and water-source heat pumps work the same way, except that the heat source/sink is the groundwater or a body of surface water, such as a lake.

Ground-source heat pumps are complex. Basically, water or a non-toxic antifreeze-water mix is circulated through buried polyethylene or polybutylene piping, which is then pumped through one of two heat exchangers in the heat pump. When used in the heating mode, this circulating water is pumped through the cold heat exchanger, where its heat is absorbed by evaporation of the refrigerant. The refrigerant is then pumped to the warm heat exchanger where the refrigerant is condensed, thereby releasing heat in the process. This sequence is reversed for operation in the cooling mode.

Although these pumps cost more to install, they have low operating costs because they take advantage of relatively constant ground temperatures. However, the installation depends on the size of your lot, the subsoil and landscape. Ground-source or water-source heat pumps can be used in more extreme climatic conditions than air-source heat pumps, and customer satisfaction with the systems is very high.

The efficiency or coefficient of performance (COP) of ground-source heat pumps is significantly higher than that of air-source heat pumps because the heat source is warmer during the heating season and the heat sink is cooler during the cooling season. Ground-source heat pumps are environmentally attractive because they deliver so much heat or cooling energy per unit of electricity consumed. The COP is usually 3 or higher.

Geothermal Heat Pump Efficiency

The heating efficiency of a geothermal heat pump is measured by the Coefficient of Performance (COP), which measures the number of units of heating or cooling produced by a unit of electricity. The COP is a more direct measure of efficiency than the HSPF and is used for geothermal heat pumps because the water temperature is more constant. Manufacturers of geothermal units provide COPs for different supply water temperatures. If a unit was installed with a COP of 3.0, the system would be operating at about 300% efficiency.

Annexure -1

INDUSTRY STANDARDS & CODES

Industry standards are voluntarily followed rules and regulations governing the design, manufacture, installation, operation, and use of manufactured products.

American National Standards Institute (ANSI) - ANSI committee Z83 works with the various standards for industrial gas equipment and ANSI committee Z223 oversees compliance with the National Fuel Gas Code.

CODES

Codes are industry standards given the force of law by legislative action of federal, state or local government.

National Fire Protection Association (NFPA) - NFPA 54 code is solely concerned with fire safety and prescribes “reasonable provisions based on minimum requirements for safety to life and property from fire”. Everyone engaged in installation, maintenance, servicing, operation, and care of heating equipment of all types should be thoroughly familiar with the NFPA code.

National Fuel Gas Code (Z223) - The installation, maintenance, operation and safety of gas-burning devices is covered by the National Fuel Gas Code Z223.

Insurance Codes - Insurers of buildings may have certain requirements or limitations on heating equipment installed in buildings which they insure. Two such insurers are

- FM - Factory Mutual
- IRI - Industrial Risk Insurers (Formerly FIA)

If a building will be insured by either of these two agencies, it is essential to contact the agency’s local inspector to obtain a clear definition of what is required to meet its standards for any heating, makeup air or infrared application that is planned.

CERTIFICATION TESTING

All test agencies observe ANSI standards when involved in investigating individual appliances.

Canadian Standards Association (CSA) - Manufacturers of gas-fired space heating equipment submit their products to CSA for detailed examination and testing to determine compliance with ANSI (United States), CSA (Canada) and other national and international standards.

Underwriters' Laboratories, Inc. (UL) - Underwriters' Laboratories tests to ANSI standards for safeguarding people and property from fire and accidents in the use of electrical equipment of all kinds. The electrical components of space heating equipment must be installed to comply with the National Electrical Code for the UL seal to be meaningful.

Local Code Requirements - Most major cities have their own codes covering fire prevention, plumbing and heating, and related matters. These codes are applicable in addition to national and industrial codes and may have special requirements not covered in the more broadly applicable codes.

Annexure -2

Heating Equipment Characteristics

Equipment Type	Typical Available Output Ranges	Advantages	Disadvantages
Gas Furnaces	40000 to 150000 BTUh	<ul style="list-style-type: none"> • Burner relative quite • Warm comfortable heat delivered to spaces • Clean burning , minimal service • Available in upflow, downflow and horizontal configurations 	<ul style="list-style-type: none"> • Use limited to availability of fuel • Flue required • Lower output unit (15000 to 30000 BTUh) compatible with actual requirements not readily available • Seasonal efficiency reduced by over sizing
Oil Furnaces	72800 to 168000 BTUh (0.65 to 1.5 gph nozzle size)	<ul style="list-style-type: none"> • Favourable alternative to electricity in colder climate • Warm comfortable heat delivered to spaces • Available in upflow, downflow and horizontal configurations 	<ul style="list-style-type: none"> • Burner relatively noisy • Flue and storage tank required • Lower output unit (15000 to 30000 BTUh) compatible with actual requirements not readily available • Seasonal efficiency reduced by over sizing • Occasional service required to assure clean combustion

Equipment Type	Typical Available Output Ranges	Advantages	Disadvantages
Electric Furnaces	17065 to 136520 BTUh (5 kW to 40 kW)	<ul style="list-style-type: none"> • Warm comfortable heat delivered to spaces • No flue required • Small space required • Same unit adaptable to upflow, downflow and horizontal configurations • Many sizes available in small increments (5 kW) allow close sizes to actual loads • Minimum service 	<ul style="list-style-type: none"> • High operating costs in most areas
Heat Pump (air to air)	18000 to 60000 BTUh (1½ to 5 tons)	<ul style="list-style-type: none"> • No flue required • Small space required similar to electric furnace • Same unit often adaptable to upflow, downflow and horizontal configurations • Economical operation compared to electric resistance furnace • Use same equipment 	<ul style="list-style-type: none"> • Low air temperature at registers • Higher air volume requires more critical duct design • Economical heating output limited to nominal tonnage of air-conditioner size • Least efficient when coldest outdoors • Less efficient for cooling than available

Equipment Type	Typical Available Output Ranges	Advantages	Disadvantages
		for both heating and cooling	high efficiency cooling only, condenser-coil combinations <ul style="list-style-type: none"> • Servicing more sophisticate than furnace
Heat Pump (water to air)	18000 to 60000 BTUh (1½ to 5 tons)	<ul style="list-style-type: none"> • No flue required • Small space required similar to electric furnace • Same unit often adaptable to upflow, downflow and horizontal configurations • Extremely efficient in both heating and cooling modes 	<ul style="list-style-type: none"> • Requires dependable ground water source within economical operating temperature range • Requires means of returning water to ground or other drainage • Potential freeze up problems in cooler climates • Installed costs higher dependent on the cost of obtaining ground water
Coal & Wood Furnace	80000 to 200000 BTUh	<ul style="list-style-type: none"> • Provide abundance of warm heat utilizing economical fuels • Ideal for retrofit in 	<ul style="list-style-type: none"> • Economical use limited to availability of wood or coal • Requires large space

Equipment Type	Typical Available Output Ranges	Advantages	Disadvantages
		<p>poorly insulated older homes</p> <ul style="list-style-type: none"> • Coal furnace can burn coal, wood and even trash • Operation not dependent on electric supply, hence not affected by outages 	<p>for coal, wood storage and larger furnace</p> <ul style="list-style-type: none"> • Requires frequent daily firing, coal handling and ash removal is messy and inconvenient • Difficult to accurately control temperature • Tends to overheat space during moderate weather

Annexure -3

APPLICATION CONSIDERATIONS FOR VARIOUS SYSTEMS

A general guide to select an appropriate heating system for different buildings is presented below, based on experience. This can be amended judiciously for specific user's needs.

Heating/Cooling Systems and Buildings

BUILDING	HEATING SYSTEM / EMITTERS	HEATING MEDIA	COMMENTS
Large Workshop, Industrial Building, Factory	Industrial warm air heaters	Oil/gas fired	Cheap to run. May be noisy. May use up floor space if floor mounted.
	Unit heaters	Steam, Hot water	A unit heater is simply a heat exchanger. Compact. May be noisy.
	Radiant tubes	Steam, Hot water	No noise, especially if non-direct fired. Suitable for between isles heating.
	Radiant panels	Steam, Hot water	Usually roof mounted. May be cheaper to operate than heating air.
Small Workshop, Garage	Industrial warm air heaters	Oil/gas fired	Cheap to run. May be noisy.
	Unit heaters	Hot water	Compact. May be noisy.
	Fan convectors	Hot water	Suitable for smaller workshops. There are various types.
Office Building, Public	Air conditioning central plant	Air	Prestigious offices. Inner city areas to reduce pollution.
	Fan coil units	Hot/chilled	Not quiet running. Individual room

BUILDING	HEATING SYSTEM / EMITTERS	HEATING MEDIA	COMMENTS
Building		water	control.
	Room air conditioners/ cassette units	Hot/chilled water	Individual room control. May be ceiling mounted.
	Plenum heating	Air	Used in low heat gain areas. Cheaper than air conditioning.
	Radiators	Hot water	Require wall space. Easy to control.
	Natural convectors	Hot water	Require wall space. Quite bulky.
	Fan convectors	Hot water	May be noisy.
	Underfloor heating	Hot water	No floor space required. Heat output may not be sufficient
	Storage heaters	Electric	Easy to charge occupier. Can be expensive to run.
Large Public Hall, Auditoria	Air conditioning central plant	Air	Calculate fresh air requirement. Air distribution is important.
	Plenum heating	Air	Cheaper than air conditioning.
Church, Library	Radiators	Hot water	High output usually required for large buildings.
	Underfloor heating	Hot water	If no wall space is available.
	Quartz lamp heaters	Electric quartz tube	Electric heating may be economical for occasional use.

BUILDING	HEATING SYSTEM / EMITTERS	HEATING MEDIA	COMMENTS
	High temperature panels	Electric metal plate	Small heat emitters. Can be roof mounted.
	Low temperature panels	Electric elements in plate	Can be roof mounted.
	Skirting heating	Electric element	Low output. May be used with other systems.
	Tubular heaters	Electric element	Mounted at low level.
	Pipe coils	Hot water	Heaters under pews.
Department Store, Supermarket	Air conditioning central plant	Air	Large Prestigious store. Use in areas of high heat gain.
	Room air conditioners/ cassette units	Hot/chilled water	Good control possibility. Compact.
	Plenum heating	Air	Used if heat gains are minimal.
	Radiators	Hot water	Use in small store.
	Fan convectors	Hot water	Use in small store. May be noisy.
School, College, University	Radiators	Hot water	Can be easily controlled with thermostatic valves.
	Radiators LST (Low Surface Temperature)	Warm water	In Nursery schools limit water temperature for safety.

BUILDING	HEATING SYSTEM / EMITTERS	HEATING MEDIA	COMMENTS
	Radiant ceiling	Water	High radiant temperatures may cause discomfort. No wall space required
	Underfloor heating	Hot water	No wall space required. Comfortable floor.
	Warm air or air conditioning.	Air	In larger areas e.g. lecture rooms.
Hotel	Radiators	Hot water	Easy room control. Bedrooms.
	Air conditioning central plant	Air	Lobby areas, large restaurants, banquet halls etc. Use in areas of high heat gain.
	Room air conditioners/ cassette units	Electric, Hot/chilled water	Good control possibility. Compact.
	Plenum heating	Air	Used if heat gains are minimal.
	Fan convectors	Hot water	Use in areas requiring quick heat up e.g. foyer. May be noisy.
	Natural convectors	Electric element	Possible key entry system which operates power to room.
House	Radiators	Hot water	Different types and materials. Efficient.
	Underfloor heating	Hot water	Invisible system.
	Air conditioner	Electrically operated	Areas of high summertime temperatures. Use quieter systems.

BUILDING	HEATING SYSTEM / EMITTERS	HEATING MEDIA	COMMENTS
		refrigerant	
Apartment	Storage heaters	Electricity	Easier to charge client. Can be more expensive to run. Difficult to control.
	Underfloor heating	Electric cables	Expensive to run if not a suitable tariff. Invisible system.
	Underfloor heating	Water	Invisible system. Requires suitable floor with insulation.
	Radiators	Hot water, Gas-fired or Oil-fired.	Natural gas easier to charge. Efficient.
Hospital Ward	Full air conditioning central plant	Air	Used where air needs to be clean. Draughts of cool air may be a problem.
	Plenum heating	Air	Can be used if heat gains are minimal.
	Radiant ceiling	Water	Cleaner than radiators. High radiant temperatures may cause discomfort.
Hospital-Operating Theater	Full air conditioning central plant	Air	Clean air essential. Special high efficiency filters required.
	Chilled ceiling / beams.	Chilled water	Advantage no air – no bacteria. Condensation may be a problem.

Annexure -4

ENERGY CONSERVATION & LOAD REDUCTION STRATEGIES

Heating requirements can be reduced through passive solar design and attention to tightening the building envelope. The following tips may be useful for energy conservation:

General Tips on Energy Conservation

1. Use a correctly sized heater for the space you are heating.
2. Heat only those areas in use at any one time.
3. The temperature of a heated room in the winter should be between 64-68°F.
4. Don't overheat. Every one-degree increase in temperature is a 10% increase in heating bills and emissions.
5. Minimize heat loss through poor insulation by repairing faulty door seals, hanging curtains that sit close to the window frames and laying rugs on bare floors.
6. Frequent changes in thermostat settings will increase operating costs.
7. Always light gas heaters in accordance with manufacturer instructions, turning the setting down to a comfortable level after the burners are lit.
8. Keep all doors closed so that the warm air is restricted to the area requiring heating.
9. Ensure ceiling space above all heated areas is adequately insulated.
10. Install draught seals and weather stripping around doors and windows. Air leaks can account for 15-25% of heat loss from an uninsulated space and create uncomfortable draughts.
11. Protect your windows - up to 40% of total heat loss from a space occurs through uncovered windows. Close-fitting, heavy drapes or blinds, or double-glazed windows reduce heat loss.
12. Zone your space: being able to close off different areas of your space allows you to heat only those areas in use at any one time.
13. Open up curtains to north-facing windows on sunny winter days to let in the natural warmth.
14. Wear warmer clothing - it's free, easy and will let you turn down your heater just a few degrees more.

15. A wall-mounted heater is the safest to use in the bathroom. It should be mounted at least 1.4 meters above the floor, well away from water taps and shower outlets.
16. Don't leave the heater running on low overnight or while you are out.
17. Use a programmable thermostat. This simple, inexpensive device may provide better savings than any other efficiency measure.
18. Turn off pilot lights (if fitted) over summer.
19. Maintain your heating system according to the manufacturer's instructions.
20. On dark winter days, cover windows with close fitting, floor length heavy curtains. Up to 30% of total heat loss from a home occurs through uncovered windows. Leaving curtains open can increase your heating bill by up to \$80 per quarter for the average home.
21. On sunny winter days, open up the curtains to north-facing windows for free natural solar energy to warm your home.
22. Lower your thermostat setting at night and when there will be no one home for at least 4 hours; a 10° setback can give you significant savings. Setback thermostats save energy by automatically turning the thermostat down and up on a preset schedule.
23. Registers - Look for and correct the following conditions:
 - closed supply dampers
 - drapes, furniture or carpet obstructing the supply and/or return registers or grilles
 - leaks in warm air ducts and cold air returns
 - dust plugging the supply and/or return registers or grilles
 - high pile carpet blocking baseboard radiators at the bottom

Load Reduction Strategies

1. ***Weatherize your home:*** Insulation and air-sealing improvements to the shell of your building will always improve your comfort, regardless of the size and type of heating system installed. Weatherization may also allow the installation of a smaller, more economical heating system.

2. **Doors and windows:** Doors and windows should fit well and/or be draught-proofed. Keep doors and windows closed when the heating is on, but don't block ventilators or airbricks.
3. **Curtains:** Heavy curtains and/or thermal linings also help prevent heat loss. Open windows on the sunny side when the sun is up so that the sun can warm the rooms. Close all curtains when it gets dark. Do not have furniture close to or in front of radiators. If you have deep windowsills, curtains should sit neatly on top of them and not cover the radiator.
4. **Filling in gaps between skirting boards and floor:** Fill in any gaps between skirting boards and the floor. This can be done with wood molding or with one of the fillers.
5. **Heat reflective foil behind radiators:** Fit heat reflective foil behind radiators on the outside walls to keep the heat inside your space, with the shiny side facing into the room.
6. **Draught proofing:** Draughts are one of the main reasons why spaces feel cold and cost a lot to heat. Draught strip windows, outside doors and the loft hatch, and fill gaps in the ground floor floorboards and below the skirting board. Do not cover vents/air bricks
7. **Roof insulation:** As much as 20% of your energy bill can be saved by effective loft insulation. If you have a loft, it should have insulation at least 150 mm (6 in) thick to keep the heat in. If your insulation is 50 mm (2 in) thick or less, you may be eligible for a grant. Don't forget to insulate the loft hatch and pipes/tank in loft.
8. **Cavity wall insulation:** More heat is lost through the walls of an average uninsulated building than by any other route. Most spaces built since the early 1930's have cavity walls (two walls with a gap in between) which can be filled with insulating material. To install cavity wall insulation, most people will need to employ a builder.
9. **Solid wall insulation:** Solid walls can be insulated but can be a problem to do. It may be worth doing a north facing wall or one that is exposed.
10. **Internal insulation:** Timber battens can be fixed to the wall in order that plasterboard, tongued and grooved boarding or a decorative wallboard can be attached. The timber bates are in-filled with insulation such as mineral wool. Make sure a vapor barrier is installed to reduce the risk of interstitial condensation. Remember that internal solid wall insulation will reduce the room

size by approximately 50 mm (2 in) along the side of the wall. Light switches, plugs and skirting boards will have to be removed and replaced. This measure is very disruptive if occupants are living in the property at the time of the work.

11. **External insulation:** It is a job for a specialist contractor, and you can obtain from the External Wall Insulation Association a list of their members and descriptions of the systems they offer.
12. **Floor insulation:** As much as 10% can be lost through floorboards. If there is easy access to the joists under the floorboards, you can insulate from below by filling the spaces between the joists with mineral wool mat or expanded polystyrene boards.
13. **Double glazing:** Large windows cause heat loss; double-glazing could be an option. Even draught-proofed, single glazed windows allow a lot of heat to be lost (around 20% of the total heat). Heat loss through windows can be halved with double-glazing. Professionally fitted double-glazing can be expensive, but if you need new windows, having double-glazing fitted is the sensible thing to do as it makes rooms more comfortable. Put double-glazing in the rooms you use the most and on large windows first. Where double-glazing can halve the heat loss through windows, double-glazing with low emissivity glass can further reduce it by 30%.
